

**AGENDA FOR THE REGULAR MEETING OF THE
BOARD OF DIRECTORS OF THE
TEMESCAL VALLEY WATER DISTRICT
OCTOBER 24, 2023, 8:30 A.M. AT
THE DISTRICT'S ADMINISTRATIVE OFFICE
22646 TEMESCAL CANYON ROAD,
TEMESCAL VALLEY, CALIFORNIA 92883**

The following is a summary of the rules of order governing meetings of the Temescal Valley Water District Board of Directors:

AGENDA ITEMS

In case of an emergency, items may be added to the Agenda by a majority vote of the Board of Directors. An emergency is defined as a work stoppage; a crippling disaster; or other activity, which severely imperils public health, safety or both. Also, items, which arise after the posting of Agenda, may be added by a two-thirds vote of the Board of Directors.

PUBLIC COMMENT

Persons wishing to address a matter not on the Agenda may be heard at this time; however, no action will be taken until placed on a future agenda in accordance with Board policy.

NOTICE TO PUBLIC

All matters listed under the Consent Calendar will be voted upon by one motion. There will be no separate discussion of these items, unless a Board Member or member of the public requests that a particular item(s) be removed from the Consent Calendar, in which case, they will be considered separately under New Business.

**IF ANYONE WISHES TO SPEAK WITH THE BOARD
ABOUT ANY CONSENT CALENDAR MATTER(S),
PLEASE STATE YOUR NAME, ADDRESS,
AND APPROPRIATE ITEM NUMBER(S).**

AFFIDAVIT OF POSTING

I, Allison Harnden, Office Manager of the Temescal Valley Water District, hereby certify that I caused the posting of the Agenda at the District office at 22646 Temescal Canyon Road, Temescal Valley, California 92883 before October 21 , 2023.

Allison Harnden, Office Manager

**AGENDA FOR REGULAR MEETING
October 24, 2023**

Page No.

1. **Roll Call and Call to Order.**
2. **Presentations and Acknowledgments.**
3. **Public Comment.**

BOARD ITEMS:

4. **Minutes of the September 26, 2023 Regular Meeting.** **6-9**
RECOMMENDATION: Approve Minutes as written.
5. **Payment Authorization Report.** **10-13**
RECOMMENDATION: Approve Report and authorize payment
of the September 26-October 24, 2023 invoices.
6. **Revenue & Expenditure Reports. (Unaudited).** **14-32**
 - a. Revenue & Expenditure Reports.
 - b. Capital Improvement Projects. **33**
 - c. Chandler Investments. **34**
7. **Trilogy Development.**
 - a. Homeowners Association update. **(-)**
 - b. Golf Course update. **(-)**
8. **Retreat Development.** **(-)**
 - a. Project Update.
 - b. 225 proposed homes to be built. **(-)**

	<u>Page No.</u>
9. Terramor Development (Forestar Toscana).	
a. Project Update.	(-)
b. 1487 homes to be built. 1127 houses occupied to date. 76% complete.	
10. Sycamore Highlands Development (Kiley).	(-)
a. Project Update.	
b. 79 homes to be built. 0 houses occupied to date.	
11. Taylor Morrison Development. (Serrano)	(-)
a. Project Update.	
b. 80 homes to be built. 11 houses occupied to date. 14% complete.	
12. Water Utilization Reports.	35-47
RECOMMENDATION: Note and file.	
13. Sustainable Groundwater Management Act.	(-)
a. Project Update.	
14. Committee Reports.	
a. Finance/Legislation (Director Harich).	(-)
b. Engineering/Operations (Director Myers).	(-)
c. Public Relations (Allison Harnden).	(-)
1. Reschedule November 28 th meeting to November 21 st & December 26 th meeting to the 19 th .	
15. General Manager's Report.	
a. General Manager's Report.	48-50
b. Water supply conditions.	51-55

	<u>Page No.</u>
c. Portable Potable Water Reservoir Management System. RECOMMENDATION: Move additional funds needed to CIP W-3-2021 and authorize the GM to purchase the system.	56-71
d. Agreement with Riverside County Emergency Management for trailer positioning. RECOMMENDATION: Authorize the General Manger to approve the agreement.	72-78
16. Operations Report.	81-104
a. Water and Sewer Operations.	
17. District Engineer's Report.	
a. Status of Projects.	105-113
b. Recycled Water Conversion Progress Payment No. 1. RECOMMENDATION: Authorize the payment of \$325,528.20 of which \$309,251.79 is issued to the contractor and \$16,276.41 is held in retention.	(-)
18. District Counsel's Report.	(-)
19. Seminars/Workshops.	(-)
20. Consideration of Correspondence. An informational package containing copies of all pertinent correspondence for the Month of September will be distributed to each Director along with the Agenda.	114
21. Adjournment.	(-)

**MINUTES OF THE
REGULAR MEETING OF THE
TEMESCAL VALLEY WATER DISTRICT**

September 26, 2023

PRESENT

D. Harich
J. Butler
F. Myers
M. Buckley

ABSENT

C. Colladay

GUESTS

T. Davis
J. Watson
J. Sincich
L. Wilson
S. Barton

STAFF

J. Pape
A. Harnden
M. McCullough
P. Bishop
D. Saunders

1. Roll Call and Call to Order.

The regular meeting of the Temescal Valley Water District was called to order by Secretary/Treasurer Myers at 8:30 a.m.

2. Presentations and Acknowledgments.

3. Public Comment – Jannlee Watson invited the District to participate in the Fall Festival on October 14th at Deleo Park.

BOARD ITEMS:

4. Minutes of the August 22, 2023 Regular Meeting.

ACTION: Director Harich moved to approve the minutes as written. Director Buckley seconded. Motion carried unanimously.

5. Payment Authorization Report.

ACTION: Director Harich moved to approve the August 22-September 26, 2023 invoices. Director Buckley seconded. Motion carried unanimously.

The Board directed staff to add GEI Consultants to the vendor list.

6. Revenue & Expenditure Reports. (Unaudited).

a. Revenue & Expenditure Reports.

ACTION: Note and file.

The Board asked staff to look at page 19 chemical expense vs. budget.

- b. Capital Improvement Projects.
 - c. Chandler Investments.
- 7. IB Consulting Annual Financial Plan Update.**
ACTION: Bring back to the November meeting.
- 8. Trilogy Development.**
- a. Homeowners Association update.
 - b. Golf Course update.
- 9. Retreat Development.**
- a. Project Update.
 - b. 225 homes proposed to be built.
- 10. Terramor Development (Forestar Toscana).**
- a. Project Update.
 - b. 1487 homes to be built. 1122 houses occupied to date. 75% complete.
- 11. Sycamore Highlands Development (Kiley).**
- a. Project Update.
 - b. 79 houses to be built. 0 houses occupied to date.
- 12. Taylor Morris Development (Serrano).**
- a. Project Update.
 - b. 80 houses to be built. 11 houses occupied to date. 14% complete.
- 13. Water Utilization Reports.**
ACTION: Note and file.
- 14. Sustainable Groundwater Management Act.**
- a. Project Update.

15. Committee Reports.

- a. Finance/Legislative (Director Harich).
- b. Engineering/Operations (Director Myers) - Director Myers reported that a legal agreement is being reviewed for Todd Elementary with CNUSD.
- c. Public Relations (Allison Harnden).
 1. Allison reported on the status of delinquent accounts.

16. General Manager's Report.

- a. General Manager's Report – The General Manager reported on current projects.
- b. Water supply conditions.
- c. Colladay Potable Water Reservoir Project bid results.
ACTION: Director Butler moved to move additional funds needed from CIP Construction budget, to authorize the General Manager to Award the contract to the lowest responsible bidder and authorize the construction of the reservoir. Director Harich seconded. Motion carried unanimously.

17. Operations Report.

- a. Water and sewer operations.

18. District Engineer's Report.

- a. Status of Projects.

19. District Counsel's Report – Mr. Saunders reported that he is working with CNUSD legal counsel on the Todd Elementary agreement.**20. Seminars/Workshops.****21. Consideration of Correspondence.**

An informational package containing copies of all pertinent correspondence for the Month of August will be distributed to each Director along with the Agenda.

22. Adjournment.

There being no further business, the September 26, 2023 Regular Meeting of the Temescal Valley Water District Board of Directors was adjourned at 10:37 a.m. by Secretary/Treasurer Myers.

ATTEST:

APPROVED:

Fred Myers, Secretary

Charles Colladay, President

Date: _____

Date: _____

TEMESCAL VALLEY WATER DISTRICT
 PAYMENT AUTHORIZATION REPORT
 OCTOBER 24, 2023

Check #	Date	Payee ID	Payee	Amount	
28900	9/22/23	JT	JUAN TORRES-TRK MAINT	\$ 210.00	
28901	9/22/23	CO	VOID	-	
28902	9/22/23	DH	DAVID HARICH	295.65	
28903	9/22/23	FM	FRED H. MYERS	295.65	
28904	9/22/23	JB	JOHN B. BUTLER	295.65	
28905	9/22/23	MB	MICHAEL S. BUCKLEY	295.65	
28906	9/21/23	REFUND	SANDRA MOORE	405.02	
28907	9/22/23	REFUND	JACQUELINE VANDAGRIFF	8,826.84	CUST-MISTAKE ON LINE
28908	9/22/23		VOID	-	
28909	9/22/23		VOID	-	
28910	9/29/23	AD	PAYROLL	-	
28911	9/29/23	BE	PAYROLL	-	
28912	9/29/23	CG	PAYROLL	-	
28913	9/29/23	CL	PAYROLL	-	
28914	9/29/23	DB	PAYROLL	-	
28915	9/29/23	DT	PAYROLL	-	
28916	9/29/23	JJ	PAYROLL	-	
28917	9/29/23	KN	PAYROLL	-	
28918	9/29/23	LK	PAYROLL	-	
28919	9/29/23	MM	PAYROLL	-	
28920	9/29/23	PB	PAYROLL	-	
28921	9/29/23	PB	PAYROLL	-	
28922	9/25/23	UHC	UNITEDHEALTHCARE	173.66	
28923	9/25/23	FI01	FIDELITY INVESTMENTS	840.00	
28924	9/29/23	FI01	FIDELITY INVESTMENTS	840.00	
28925	9/29/23	FI01	FIDELITY INVESTMENTS	285.94	
28926	9/29/23	FI01	FIDELITY INVESTMENTS	1,116.00	
28927	9/29/23	FI01	FIDELITY INVESTMENTS	596.17	
28928	9/29/23	FI01	FIDELITY INVESTMENTS	840.00	
28929	9/29/23	FI01	FIDELITY INVESTMENTS	840.00	
28930	9/25/23	SIC	SILVERSCRIPT INSURANCE COMPANY	91.80	
28931	9/25/23		VOID	-	
28932	9/27/23	SWRCB	STATE WATER RESOURCES CONTROL BOARD	130.00	
28933	9/30/23	SO03	SOUTHERN CALIF EDISON CO.	104,667.43	

TEMESCAL VALLEY WATER DISTRICT
PAYMENT AUTHORIZATION REPORT
OCTOBER 24, 2023

Check #	Date	Payee ID	Payee	Amount	
28934	9/30/23	TWC	SPECTRUM BUSINESS	1,262.80	
28935	9/30/23	XI	XALOGY INC	6,964.18	
28936	10/13/23	AD	PAYROLL	-	
28937	10/13/23	BE	PAYROLL	-	
28938	10/13/23	CG	PAYROLL	-	
28939	10/13/23	CL	PAYROLL	-	
28940	10/13/23	DB	PAYROLL	-	
28941	10/13/23	DT	PAYROLL	-	
28942	10/13/23	JJ	PAYROLL	-	
28943	10/13/23	KN	PAYROLL	-	
28944	10/13/23	LK	PAYROLL	-	
28945	10/13/23	MM	PAYROLL	-	
28946	10/13/23	PB	PAYROLL	-	
28947	10/16/23	REFUND	JOLENE BULLOCK	161.37	
28948	10/16/23	REFUND	PERRY PARRIS	161.49	
28949	10/16/23	REFUND	MARKUS LETTAU	127.66	
28950	10/16/23	REFUND	DIANA KLAIB	190.85	
28951	10/16/23	REFUND	DONNA RYSKEY	170.98	
28952	10/16/23	REFUND	BAO NGO	130.00	
28953	10/16/23	REFUND	KALUGI T. SHERMAN	34.89	
28954	10/16/23	REFUND	KATHRYN N VOYSEY	142.62	
28955	10/16/23	REFUND	LATONJA RANDALL-EL	25.31	
28956	10/16/23		VOID	-	
28957	10/16/23		VOID	-	
28958	10/16/23	ACSI	ALEXANDER'S CONTRACT SERVICES, INC.	7,619.76	
28959	10/16/23	ATT01	AT&T	1,001.75	
28960	10/16/23	BGM	BIG GIANT MEDIA	84.90	
28961	10/16/23	BT	BT PIPELINE INC.	5,500.00	SMALL LEAK REPAIRS
28962	10/16/23	CA12	CALIFORNIA HIGHWAY PATROL	315.00	
28963	10/16/23	CA16	CALIFORNIA CHOICE BENEFIT ADMINISTRATOR	4,395.74	
28964	10/16/23	CAM	CHANDLER INVESTMENT MANAGEMENT	2,001.88	
28965	10/16/23	CBE-2	VOID	-	
28966	10/16/23	CE01	CENTRAL COMMUNICATIONS	598.36	
28967	10/16/23	CESI	CENTER ELECTRIC SERVICES INC.	6,590.33	REPLACE SYC CRK RW VFD & PROG

TEMESCAL VALLEY WATER DISTRICT
PAYMENT AUTHORIZATION REPORT
OCTOBER 24, 2023

Check #	Date	Payee ID	Payee	Amount	
28968	10/16/23	CL01	CLAYSON, BAINER & SAUNDERS	1,787.50	
28969	10/16/23	CM01	CORE & MAIN	3,045.02	
28970	10/16/23	CRTD	COUNTY OF RIVERSIDE-TRANS DEPT	5,738.83	ENCROACHMENT PERMIT FEES
28971	10/16/23	CUSI	CONTINENTAL UTILITY SOLUTIONS, INC.	10.50	
28972	10/16/23	DHWS	D&H WATER SYSTEMS	1,062.08	
28973	10/16/23	DSC	DATABASE SYSTEMS CORP.	500.00	
28974	10/16/23	DU02	DUDEK & ASSOCIATES-SPECIAL PROJECTS	42,753.00	CAP-WR RES ENG/GIS/RW CONVERSION
28975	10/16/23	DU03	DUDEK & ASSOCIATES-PASS THRU	1,032.50	
28976	10/16/23	DU04	DUDEK & ASSOCIATES-ENGINEERING	4,076.50	
28977	10/16/23	DXP	DXP CORTECH	2,640.00	
28978	10/16/23	EW01	EWING IRRIGATION PRODUCTS	335.19	
28979	10/16/23	FE01	FEDERAL EXPRESS	61.81	
28980	10/16/23	GMDM	GUTIRREZ MAINTENANCE/ DANIEL GUTIERREZ	950.00	
28981	10/16/23	HO01	HOME DEPOT CREDIT SERVICES	1,153.67	
28982	10/16/23	HPS	HYDROPRO SOLUTIONS	12,167.63	METERS
28983	10/16/23	KCI	KASSEL CONTRACTING INC.	6,950.00	
28984	10/16/23	MH01	MCFADDEN-DALE HARDWARE CO.	1,268.44	
28985	10/16/23	MTM	MASTER TECH MECHANICAL	743.36	
28986	10/16/23	MU01	WILLDAN FINANCIAL SERVICES	14,230.01	CFD CHGS PD BY CFD
28987	10/16/23	NC	NORTHSTAR CHEMICAL	19,032.96	
28988	10/16/23	OPI	ON POWER INDUSTRIES	7,810.00	GENERATOR PRE MAINT
28989	10/16/23	PCE	PACIFIC COAST ENVELOPE INC	248.04	
28990	10/16/23	PLM01	PARRA LANDSCAPE MAINTENANCE	3,005.50	WEED ABATEMENT
28991	10/16/23	PPE	PRIVATE PEST EXTERMINATORS	438.00	
28992	10/16/23	QU	QUADIENT LEASING	1,522.18	
28993	10/16/23	SAQMDHB	SOUTH COAST AIR QUALITY MGT DIST	1,995.78	
28994	10/16/23	SAWPA	SANTA ANA WATERSHED PROJECT AUTHORITY	8,769.23	EMERGING CONSTITUENTS PROG
28995	10/16/23	SD01	STARR DESIGN	298.31	
28996	10/16/23	ST02	STATE COMPENSATION INSUR.FUND	1,362.91	
28997	10/16/23	TR012	TRAN CONTROLS SCADA SOLUTIONS, LLC.	750.00	
28998	10/16/23	UBB	USA BLUEBOOK	1,707.46	
28999	10/16/23	UN01	UNDERGROUND SERVICE ALERT	109.75	
29000	10/16/23	VPB	VOGEL'S PLUMBING & BACKFLOW	398.00	
29001	10/16/23	WA01	WASTE MANAGEMENT - INLAND EMPIRE	632.69	

TEMESCAL VALLEY WATER DISTRICT
PAYMENT AUTHORIZATION REPORT
OCTOBER 24, 2023

Check #	Date	Payee ID	Payee	Amount
29002	10/16/23	WE01	WESTERN MUNICIPAL WATER DISTR.	426,968.35
29003	10/16/23	XI	XALOGY INC	6,964.18
29004	10/17/23	CBE-1	CBE-MAINTENANCE	478.95
29005	10/17/23	CBE-2	CBE-LEASE	477.42
29006	10/17/23	DU01	DUDEK & ASSOCIATES-CONT MGT	24,959.00
29007	10/17/23	DU03	DUDEK & ASSOCIATES-PASS THRU	8,200.00
29008	10/17/23	DU04	DUDEK & ASSOCIATES-ENGINEERING	1,776.00
29009	10/17/23	USB01	US BANK GOVERNMENT SERVICES	2,106.86
Total				<u>\$779,042.94</u>

THESE INVOICES ARE SUBMITTED TO THE
TEMESCAL VALLEY BOARD OF DIRECTORS FOR
APPROVAL AND AUTHORIZATION FOR PAYMENT

Mel McCullough - Finance Manager

Mel McCullough - Finance Manager 10/24/23

**TEMESCAL VALLEY WATER DISTRICT
INTERNAL BALANCE SHEET
30-Sep-23**

ASSETS

Fixed Assets (net of accumulated depreciation)			
Land		\$	902,118
Treatment Plants			37,386,368
Capacity Rights			13,503,639
Water System, Reservoir & Wells			11,908,805
Water & Sewer Mains			41,149,150
General Equipment Sewer/Water/ Furniture			1,599,309
Buildings & Entrance Improvements			-
		\$	106,449,389
Current Assets			
Cash - Wastewater	9,055,694		
Cash - Water	19,989,612		
Cash - ID #1	589,838		
Cash - ID #2	366,729		
Cash - Nonpotable	7,666,319		
Cash - Deposits	1,382,658		39,050,851
Accounts Receivable-Services/Developers			1,608,817
Assessment Receivable			184,138
Interest Receivable			97,635
Prepaid Expenses			71,391
Inventory			70,800
		\$	41,083,631
Other Assets			
Work-in-Process			674,300
Deferred Outflows - Pension			164,014
Cell Tower Lease Receivable			911,068
TOTAL ASSETS		\$	149,282,402

LIABILITIES

Current Liabilities			
Accounts Payable		\$	565,338
Security Deposits			297,391
Payroll & Payroll Taxes Payable			41,763
Capacity & Meter Deposits			161,513
Fiduciary Payments Payable			552,374
Developer Deposits			366,663
Other Deposits			4,717
			1,989,760
Long-term Liabilities			
TVRP Note			-
Deferred Inflow -Cell Tower Leases			911,068
Deferred Inflows - Pension			141,677
TOTAL LIABILITIES		\$	3,042,505

FUND EQUITY

Fund Balances			
Waste Water Fund Balance			61,202,837
Water Fund Balance			65,467,272
ID #1 Fund Balance			671,901
ID #2 Fund Balance			649,925
Recycled Water Fund Balance			18,247,962
TOTAL FUND EQUITY		\$	146,239,897
TOTAL LIABILITIES & FUND EQUITY		\$	149,282,402

NOTE:

CASH DRAWER	\$	400
GENERAL		2,634,076
CHANDLER		23,879,619
LAIF		12,536,756
	\$	39,050,851

**TEMESCAL VALLEY WATER DISTRICT
REVENUE AND EXPENDITURE/BUDGET
FOR TWO MONTHS ENDING
AUGUST 31, 2023**

REVISED

	SEPTEMBER			YEAR TO DATE			BUDGET 2023-2024	BUDGET REMAINING
	ACTUAL	BUDGET	VARIANCE	ACTUAL	BUDGET	VARIANCE		
<u>WASTEWATER DEPARTMENT</u>								
OPERATING REVENUE:								
MONTHLY SEWER SERVICE CHARGE	\$ 260,171	\$ 272,750	(12,579)	\$ 784,529	\$ 818,250	(33,721)	\$ 3,273,000	\$ (2,488,471)
MONTHLY SERVICE CHARGE-ID #1	11,764	12,830	(1,066)	35,292	38,490	(3,198)	154,000	(118,708)
MONTHLY SERVICE CHARGE-ID #2	13,307	14,550	(1,243)	39,921	43,650	(3,729)	174,700	(134,779)
MONTHLY SEWER SERVICE CHG-R COM	16,270	16,670	(400)	50,557	50,010	547	200,000	(149,443)
MISC UTILITY CHARGES/ REVENUE	2,909	5,800	(2,891)	5,758	17,400	(11,642)	70,000	(64,242)
STANDBY CHARGES	-	-	-	-	-	-	110,000	(110,000)
CFD REIMBURSEMENTS	-	-	-	-	-	-	30,000	(30,000)
INSPECTION CHARGES	4,522	2,500	2,022	6,710	7,500	(790)	30,000	(23,290)
TOTAL WASTEWATER REVENUE	308,943	325,100	(16,157)	922,767	975,300	(52,533)	4,041,700	(3,118,933)
OPERATING EXPENSES:								
WAGES EXPENSE-OPERATIONS	24,344	23,450	894	56,492	56,560	(68)	202,900	(146,408)
WAGES EXPENSE-INSPECTION	4,985	4,850	135	11,568	11,310	258	42,000	(30,432)
PAYROLL TAXES EXP	461	555	(94)	1,008	1,295	(287)	4,800	(3,792)
EMPLOYEE BENEFITS-INS	1,895	2,200	(305)	4,494	6,600	(2,106)	26,000	(21,506)
EMPLOYEE BENEFITS-RETIREMENT	2,518	4,350	(1,832)	8,216	10,210	(1,994)	38,000	(29,784)
OVERTIME OPERATION EXP	1,905	1,500	405	3,755	3,700	55	14,000	(10,245)
OVERTIME INSPECTION EXP	-	250	(250)	763	750	13	3,000	(2,237)
MILEAGE EXP	250	400	(150)	561	1,200	(639)	5,000	(4,439)
VACATION EXP	1,567	1,585	(18)	4,467	4,755	(288)	19,000	(14,533)
SCADA SYSTEM STANDBY EXP	400	350	50	600	1,050	(450)	4,200	(3,600)
SCADA SYSTEM ADMIN/MAINT	-	670	(670)	-	2,010	(2,010)	8,000	(8,000)
LABORATORY TESTING COSTS	-	1,500	(1,500)	1,015	4,500	(3,485)	18,000	(16,985)
COMPLIANCE TESTING- SARD TEST	-	1,000	(1,000)	3,061	3,000	61	13,000	(9,939)
VACTOR TRUCK EXP	-	1,000	(1,000)	-	3,000	(3,000)	10,000	(10,000)
SEWER CLEANING AND VIDEO	-	2,200	(2,200)	3,490	6,600	(3,110)	26,000	(22,510)
PLANT PUMPING COST	-	2,000	(2,000)	2,570	6,000	(3,430)	25,000	(22,430)
SLUDGE DISPOSAL COSTS	633	4,200	(3,567)	11,523	12,600	(1,077)	50,000	(38,477)
SLUDGE DISPOSAL BAG EXP	-	-	-	21,293	25,000	(3,707)	25,000	(3,707)
SLUDGE CHEMICAL EXP	-	4,000	(4,000)	-	12,000	(12,000)	45,000	(45,000)
EQUIPMENT RENTAL COSTS	-	200	(200)	-	600	(600)	2,000	(2,000)
ELECTRICAL REPAIR EXP	-	420	(420)	-	1,260	(1,260)	5,000	(5,000)
EQUIPMENT REPAIRS & MAINT/CLEANING	11,751	30,000	(18,249)	49,108	90,000	(40,892)	350,000	(300,892)
SEWER LINE/EMERGENCY REPAIRS	-	-	-	-	-	-	15,000	(15,000)
SECURITY AND ALARM EXP	-	350	(350)	-	1,050	(1,050)	4,000	(4,000)
PROPERTY MAINTENANCE	6,536	8,500	(1,964)	24,012	25,500	(1,488)	102,000	(77,988)
EMERGENCY SERVICE COST	-	-	-	-	-	-	2,000	(2,000)
ENGINEERING/ADMIN. STUDIES	-	2,000	(2,000)	1,695	6,000	(4,305)	25,000	(23,305)
ENERGY COSTS	42,041	31,000	11,041	134,481	93,000	41,481	370,000	(235,519)
CONSUMABLE SUPPLIES & CLEANING	1,904	1,300	604	3,861	3,900	(39)	15,000	(11,139)
CHEMICALS, LUBRICANTS & FUELS	21,607	14,600	7,007	72,328	43,800	28,528	175,000	(102,672)
SMALL EQUIPMENT & TOOLS COST	3,045	2,500	545	3,323	7,500	(4,177)	30,000	(26,677)
PERMITS, FEES & TAXES	11,065	5,000	6,065	43,627	15,000	28,627	60,000	(16,373)
SAWPA BASIN MONITORING EXP	-	-	-	-	35,000	(35,000)	35,000	(35,000)
MAP UPDATING/GIS EXP	-	200	(200)	-	600	(600)	2,000	(2,000)
MISC. OPERATING EXP	-	-	-	-	-	-	1,000	(1,000)
BAD DEBT EXPENSES	-	-	-	-	-	-	5,000	(5,000)
CONTINGENCIES	-	6,500	(6,500)	-	19,500	(19,500)	76,600	(76,600)
TOTAL OPERATING EXPENSES	136,907	158,630	(21,723)	467,311	514,850	(47,539)	1,853,500	(1,386,189)

**TEMESCAL VALLEY WATER DISTRICT
REVENUE AND EXPENDITURE/BUDGET
FOR TWO MONTHS ENDING
AUGUST 31, 2023**

REVISED

	SEPTEMBER			YEAR TO DATE			BUDGET	BUDGET
	ACTUAL	BUDGET	VARIANCE	ACTUAL	BUDGET	VARIANCE	2023-2024	REMAINING
ADMINISTRATIVE EXPENSES:								
CONTRACT MANAGEMENT	9,984	10,000	(16)	26,435	30,000	(3,565)	119,000	(92,565)
GENERAL ENGINEERING EXP	-	1,700	(1,700)	93	5,100	(5,007)	20,000	(19,907)
EMPLOYEE BENEFITS-INS	1,558	2,000	(442)	3,731	6,000	(2,269)	23,500	(19,769)
EMPLOYEE BENEFITS-RETIREMENT	1,602	3,900	(2,298)	6,098	9,900	(3,802)	37,800	(31,702)
WAGES EXPENSE	23,847	27,250	(3,403)	50,135	63,750	(13,615)	237,000	(186,865)
VACATION EXP	1,315	1,350	(35)	3,945	4,050	(105)	16,000	(12,055)
OVERTIME EXP	27	200	(173)	197	600	(403)	2,400	(2,203)
PAYROLL TAX EXPENSES	359	300	59	1,129	900	229	3,700	(2,571)
MILEAGE EXP ADMIN	-	20	(20)	-	60	(60)	250	(250)
CONTRACT STAFFING EXP	-	-	-	-	-	-	4,000	(4,000)
LEGAL EXPENSES	715	1,250	(535)	2,684	3,750	(1,066)	15,000	(12,316)
AUDIT EXPENSES	-	-	-	-	-	-	6,500	(6,500)
BOARD COMMITTEE MEETING EXP.	480	1,250	(770)	1,725	3,750	(2,025)	15,000	(13,275)
ELECTION & PUBLIC HEARING EXP	-	-	-	-	-	-	12,000	(12,000)
COMPUTER SYSTEM ADMIN	7,790	3,500	4,290	9,740	10,500	(760)	40,000	(30,260)
BANK CHARGES EXP	3,125	3,500	(375)	9,457	10,500	(1,043)	40,000	(30,543)
MISCELLANEOUS & EDUCATION EXP	-	200	(200)	-	600	(600)	2,000	(2,000)
TELEPHONE, FAX & CELL EXP	1,921	1,700	221	4,209	5,100	(891)	20,000	(15,791)
OFFICE SUPPLIES EXP	871	2,000	(1,129)	3,321	6,000	(2,679)	24,000	(20,679)
PRINTING EXPENSES	-	1,250	(1,250)	4,438	3,750	688	15,000	(10,562)
POSTAGE & DELIVERY EXPENSE	1,255	1,420	(165)	3,543	4,260	(717)	17,000	(13,457)
PUBLICATIONS, NOTICES & DUES	101	500	(399)	215	1,500	(1,285)	6,000	(5,785)
EQUIPMENT LEASE EXPENSES	991	670	321	2,100	2,010	90	8,000	(5,900)
INSURANCE EXPENSES	3,741	4,000	(259)	10,678	12,000	(1,322)	48,000	(37,322)
ANNUAL ASSESSMENT EXP	-	-	-	-	-	-	4,000	(4,000)
COMMUNITY OUTREACH EXP	-	-	-	6,034	8,000	(1,966)	12,500	(6,466)
INVESTMENT EXP	801	625	176	2,397	1,875	522	7,500	(5,103)
TOTAL ADMINISTRATIVE EXPENSES	60,483	68,585	(8,102)	152,304	193,955	(41,651)	756,150	(603,846)
TOTAL WASTEWATER EXPENSES	197,390	227,215	(29,825)	619,615	708,805	(89,190)	2,609,650	(1,990,035)
NET OPERATING REVENUE/EXPENSE	111,553	97,885	13,668	303,152	266,495	36,657	1,432,050	(1,128,898)
NON-OPERATING SOURCE OF FUNDS:								
INTEREST INCOME	16,729	12,500	4,229	96,465	37,500	58,965	150,000	(53,535)
PROPERTY TAX INCOME	-	-	-	26,651	-	26,651	170,000	(143,349)
TOTAL NON-OPER SOURCE OF FUNDS	16,729	12,500	4,229	123,116	37,500	85,616	320,000	(196,884)
TOTAL SEWER REVENUE/EXPENSE	\$ 128,282	110,385	17,897	\$ 426,268	303,995	122,273	\$ 1,752,050	(1,325,782)
TRANSFER TO CAPITAL FUND-REPLACEMENT				222,713				
TRANSFER TO CAPITAL FUND-IMPROVEMENT				203,555				
CONNECTION FEES				-				
				-				
WASTE WATER CAPITAL FUND:								
ENDING FUNDS AVAILABLE 2021-2022	9,961,270							
TRANSFER FOR CAPITAL FUND REPLACEMENT	222,713							
TRANSFER FOR CAPITAL IMPROVEMENTS	203,555							
CAPITAL IMPROVEMENT (SEE ATTACHED DETAIL)	(31,487)							
TOTAL FUNDS AVAILABLE	10,356,051							

**TEMESCAL VALLEY WATER DISTRICT
REVENUE AND EXPENDITURE/BUDGET
FOR TWO MONTHS ENDING
AUGUST 31, 2023**

REVISED

WATER DEPARTMENT

	SEPTEMBER			YEAR TO DATE			BUDGET	BUDGET
	ACTUAL	BUDGET	VARIANCE	ACTUAL	BUDGET	VARIANCE	2023-2024	REMAINING
OPERATING REVENUE:								
WATER SERVICE CHARGE	171,629	167,000	4,629	514,016	501,000	13,016	2,000,000	(1,485,984)
WATER USAGE CHARGES	414,039	448,000	(33,961)	1,373,660	1,416,000	(42,340)	5,415,000	(4,041,340)
WATER PUMPING CHARGE	17,626	27,000	(9,374)	57,818	86,000	(28,182)	270,000	(212,182)
FIRE PROTECTION CHARGES	3,333	3,750	(417)	10,029	11,250	(1,221)	45,000	(34,971)
MISC. UTILITY CHARGES	8,860	10,000	(1,140)	37,063	36,000	1,063	140,000	(102,937)
SERVICE METER INCOME	1,500	4,000	(2,500)	9,600	12,000	(2,400)	48,000	(38,400)
CELLULAR SITE LEASE	6,855	6,350	505	17,058	19,050	(1,992)	76,000	(58,942)
MWD READINESS TO SERVE CHARGE	13,972	13,740	232	41,835	41,220	615	166,000	(124,165)
STANDBY CHARGES	-	-	-	-	-	-	40,000	(40,000)
CFD REIMBURSEMENTS	-	-	-	-	-	-	30,000	(30,000)
INSPECTION CHARGES	3,956	2,500	1,456	5,872	7,500	(1,628)	30,000	(24,128)
TOTAL WATER REVENUE	641,770	682,340	(40,570)	2,066,951	2,130,020	(63,069)	8,260,000	(6,193,049)

**TEMESCAL VALLEY WATER DISTRICT
REVENUE AND EXPENDITURE/BUDGET
FOR TWO MONTHS ENDING
AUGUST 31, 2023**

REVISED

	SEPTEMBER			YEAR TO DATE			BUDGET	BUDGET
	ACTUAL	BUDGET	VARIANCE	ACTUAL	BUDGET	VARIANCE	2023-2024	REMAINING
OPERATING EXPENSES:								
WAGES EXPENSE-OPERATIONS	21,302	20,500	802	49,430	47,800	1,630	177,500	(128,070)
WAGES EXPENSE-INSPECTION	4,362	4,250	112	10,122	9,850	272	36,500	(26,378)
PAYROLL TAXES EXP	403	485	(82)	842	1,135	(293)	4,200	(3,358)
EMPLOYEE BENEFITS-INS	994	1,075	(81)	2,060	3,225	(1,165)	22,500	(20,440)
EMPLOYEE BENEFITS-RETIREMENT	2,141	2,800	(659)	6,423	8,400	(1,977)	33,500	(27,077)
MILEAGE EXP	-	125	(125)	-	375	(375)	1,500	(1,500)
OVERTIME EXPENSE OPER/ ON CALL	1,718	1,025	693	3,711	3,075	636	12,300	(8,589)
OVERTIME EXP INSPECTION	-	225	(225)	668	675	(7)	2,700	(2,032)
OVERTIME CROSS CONNECTION EXP	-	1,250	(1,250)	-	3,750	(3,750)	15,000	(15,000)
SCADA SYSTEM STANDBY EXP	300	300	-	600	900	(300)	3,700	(3,100)
VACATION EXP	1,371	1,375	(4)	3,909	4,125	(216)	16,500	(12,591)
CONTRACT STAFFING-METER READS	7,620	7,500	120	22,821	22,500	321	90,000	(67,179)
SCADA SYSTEM ADMIN/MAINT	-	850	(850)	-	2,550	(2,550)	10,000	(10,000)
LABORATORY TESTING COSTS	-	1,420	(1,420)	889	4,260	(3,371)	17,000	(16,111)
COMPLIANCE TESTING	-	1,250	(1,250)	-	3,750	(3,750)	15,000	(15,000)
LEAK DETECTION EXPENSE	-	850	(850)	-	2,550	(2,550)	10,000	(10,000)
EPA WATER TESTING EXP	-	710	(710)	-	2,130	(2,130)	8,500	(8,500)
EQUIPMENT RENTAL COSTS	-	200	(200)	-	600	(600)	2,000	(2,000)
EQUIPMENT REPAIRS & MAINT.	12,234	10,000	2,234	30,923	30,000	923	120,000	(89,077)
WATER LINE REPAIRS	-	3,300	(3,300)	-	9,900	(9,900)	40,000	(40,000)
ALARM MONITORING COSTS	-	750	(750)	-	750	(750)	3,000	(3,000)
EMERGENCY SERVICE COST	-	-	-	-	-	-	1,500	(1,500)
PROPERTY MAINTENANCE	726	3,300	(2,574)	1,288	9,900	(8,612)	40,000	(38,712)
ENGINEERING/ADMIN. STUDIES	-	700	(700)	-	2,100	(2,100)	8,000	(8,000)
PLAN CHECK EXPENSE (TVWD)	-	850	(850)	-	2,550	(2,550)	10,000	(10,000)
ENERGY COSTS	21,527	21,000	527	67,280	65,600	1,680	205,000	(137,720)
CONSUMABLE SUPPLIES & CLEANING	-	500	(500)	272	1,500	(1,228)	6,000	(5,728)
CHEMICALS, LUBRICANTS & FUELS	-	850	(850)	1,505	2,550	(1,045)	10,000	(8,495)
SMALL EQUIPMENT & TOOLS COST	-	400	(400)	-	1,200	(1,200)	5,000	(5,000)
PERMITS, FEES & TAXES	2,138	1,700	438	3,189	5,100	(1,911)	20,000	(16,811)
MAP UPDATING/GIS EXP	-	400	(400)	-	1,200	(1,200)	5,000	(5,000)
SERVICE METERS & PARTS COSTS	-	2,500	(2,500)	5,184	7,500	(2,316)	30,000	(24,816)
WHOLESALE WATER PURCHASES	405,974	470,000	(64,026)	1,337,091	1,486,800	(149,709)	4,845,000	(3,507,909)
WATER-MWD CAPACITY CHARGE	5,830	5,830	-	17,490	17,490	-	76,000	(58,510)
WATER-READINESS TO SERVE/REFUSAL CHARGE	15,164	15,200	(36)	45,492	45,600	(108)	203,000	(157,508)
WMWD-MGLMR EXP	-	-	-	-	-	-	150,000	(150,000)
BAD DEBT EXPENSES	-	-	-	-	-	-	10,000	(10,000)
CONSERVATION REBATE EXP	-	500	(500)	-	1,500	(1,500)	5,000	(5,000)
CONTINGENCIES	-	5,000	(5,000)	-	15,000	(15,000)	60,595	(60,595)
TOTAL OPERATING EXPENSES	503,804	588,970	(85,166)	1,611,189	1,827,890	(216,701)	6,331,495	(4,720,306)

**TEMESCAL VALLEY WATER DISTRICT
REVENUE AND EXPENDITURE/BUDGET
FOR TWO MONTHS ENDING
AUGUST 31, 2023**

REVISED

	SEPTEMBER			YEAR TO DATE			BUDGET	BUDGET
	ACTUAL	BUDGET	VARIANCE	ACTUAL	BUDGET	VARIANCE	2023-2024	REMAINING
ADMINISTRATIVE EXPENSES:								
CONTRACT MANAGEMENT	8,736	8,700	36	23,130	26,100	(2,970)	104,000	(80,870)
GENERAL ENGINEERING EXP	-	2,000	(2,000)	4,170	6,000	(1,830)	25,000	(20,830)
EMPLOYEE BENEFITS-INS	1,602	1,710	(108)	3,656	4,130	(474)	20,500	(16,844)
EMPLOYEE BENEFITS-RETIREMENT	2,297	2,870	(573)	6,891	7,070	(179)	33,500	(26,609)
WAGES EXPENSE	20,866	23,700	(2,834)	50,692	55,300	(4,608)	205,000	(154,308)
VACATION EXP	1,151	1,200	(49)	3,453	3,600	(147)	14,000	(10,547)
MILEAGE EXP ADMIN	-	50	(50)	-	150	(150)	500	(500)
OVERTIME EXPENSE	-	250	(250)	149	570	(421)	2,100	(1,951)
PAYROLL TAX EXPENSES	315	370	(55)	746	870	(124)	3,200	(2,454)
CONTRACT STAFFING-OFFICE	-	-	-	-	-	-	3,500	(3,500)
LEGAL EXPENSES	626	1,000	(374)	2,348	3,000	(652)	12,000	(9,652)
AUDIT EXPENSES	-	-	-	-	-	-	5,900	(5,900)
BOARD COMMITTEE/ MEETING EXP.	420	1,100	(680)	1,508	3,300	(1,792)	13,000	(11,492)
COMPUTER SYSTEM EXP	6,816	2,500	4,316	11,692	7,500	4,192	30,000	(18,308)
BANK CHARGES EXP	2,734	2,920	(186)	8,275	8,760	(485)	35,000	(26,725)
MISCELLANEOUS & EDUCATION EXP	-	350	(350)	-	1,050	(1,050)	4,000	(4,000)
TELEPHONE EXP	1,680	1,420	260	3,683	4,260	(577)	17,000	(13,317)
OFFICE SUPPLIES EXP	908	1,700	(792)	2,905	5,100	(2,195)	20,000	(17,095)
PRINTING EXPENSES	-	1,000	(1,000)	3,883	3,000	883	12,000	(8,117)
POSTAGE & DELIVERY EXPENSE	1,044	1,250	(206)	3,017	3,750	(733)	15,000	(11,983)
PUBLICATIONS, NOTICES & DUES	-	375	(375)	-	1,125	(1,125)	4,500	(4,500)
EQUIPMENT LEASE EXPENSES	867	600	267	1,714	1,800	(86)	7,000	(5,286)
INSURANCE EXPENSES	3,274	3,500	(226)	9,345	10,500	(1,155)	42,000	(32,655)
INVESTMENT EXPENSE	700	540	160	2,097	1,620	477	6,500	(4,403)
ANNUAL ASSESSMENT EXP	-	375	(375)	-	1,125	(1,125)	4,500	(4,500)
ELECTION & PUBLIC HEARING EXP	-	-	-	-	-	-	10,500	(10,500)
COMMUNITY OUT REACH EXP	-	1,250	(1,250)	5,280	8,000	(2,720)	15,000	(9,720)
TOTAL ADMINISTRATIVE EXPENSES	54,036	60,730	(6,694)	148,634	167,680	(19,046)	665,200	(516,566)
TOTAL WATER EXPENSES	557,840	649,700	(91,860)	1,759,823	1,995,570	(235,747)	6,996,695	(5,236,872)
NET OPERATING REVENUE/EXPENSE	83,930	32,640	51,290	307,128	134,450	172,678	1,263,305	(956,177)
NON-OPERATING SOURCE OF FUNDS:								
INTEREST INCOME	21,132	14,000	7,132	121,852	42,000	79,852	170,000	(48,148)
PROPERTY TAX INCOME	-	-	-	13,126	-	13,126	100,000	(86,874)
TOTAL NON-OP SOURCE OF FUNDS	21,132	14,000	7,132	134,978	42,000	92,978	270,000	(135,022)
TOTAL REVENUE/EXPENSE	105,062	46,640	58,422	442,106	176,450	265,656	1,533,305	(1,091,199)
TRANSFER TO CAPITAL FUND-REPLACEMENT				207,175				
TRANSFER TO CAPITAL FUND-IMPROVEMENT				234,931				
CONNECTION FEES				26,809				
CAPACITY USAGE INCOME				89,779				
LONG TERM DEBT REDUCTION				89,779				
WATER CAPITAL FUND:				-				
ENDING FUNDS AVAILABLE 2021-2022	19,252,251							
TRANSFER FOR CAPITAL FUND REPLACEMENT	207,175							
TRANSFER FOR CAPITAL IMPROVEMENTS	261,740							
CAPITAL IMPROVEMENT (SEE ATTACHED DETAIL)	(77,024)							
TOTAL FUNDS AVAILABLE	19,644,142							

**TEMESCAL VALLEY WATER DISTRICT
REVENUE AND EXPENDITURE/BUDGET
FOR TWO MONTHS ENDING
AUGUST 31, 2023**

REVISED

	SEPTEMBER			YEAR TO DATE			BUDGET	BUDGET
	ACTUAL	BUDGET	VARIANCE	ACTUAL	BUDGET	VARIANCE	2023-2024	REMAINING
ID#1 DEPARTMENT								
OPERATING REVENUE:								
ANNUAL SEWER SERVICE CHARGE	13,725	13,725	-	41,175	41,175	-	164,700	(123,525)
TOTAL ID #1 REVENUE	13,725	13,725	-	41,175	41,175	-	164,700	(123,525)
OPERATING EXPENSES:								
PLANT REMOVAL COST	-	-	-	-	-	-	-	-
MONTHLY TREATMENT PLANT COSTS	11,764	11,764	-	35,292	35,292	-	154,596	(119,304)
TOTAL OPERATING COSTS	11,764	11,764	-	35,292	35,292	-	154,596	(119,304)
ADMINISTRATIVE EXPENSES:								
ANNUAL ASSESSMENT PROCESSING	-	-	-	-	-	-	3,000	(3,000)
TOTAL ADMINISTRATIVE EXPENSES	-	-	-	-	-	-	3,000	(3,000)
TOTAL ID#1 EXPENSES	11,764	11,764	-	35,292	35,292	-	157,596	(122,304)
NET OPERATING REVENUE/EXPENSE	1,961	1,961	-	5,883	5,883	-	7,104	(1,221)
NON-OPERATING SOURCE OF FUNDS:								
INTEREST INCOME-LAIF	439	350	89	2,537	1,050	1,487	4,200	(1,663)
TOTAL NON-OPER SOURCE OF FUNDS	439	350	89	2,537	1,050	1,487	4,200	(1,663)
TOTAL REVENUE/EXPENSE	2,400	2,311	89	8,420		1,487	11,304	(2,884)
TRANSFER TO SINKING FUND FOR CAPACITY				8,420				
				-				
ID #1 FUND BALANCE:								
ENDING FUNDS AVAILABLE 2021-2022	581,418							
SINKING FUND FOR CAPACITY	8,420							
TOTAL FUNDS AVAILABLE	589,838							

	SEPTEMBER			YEAR TO DATE			BUDGET	BUDGET
	ACTUAL	BUDGET	VARIANCE	ACTUAL	BUDGET	VARIANCE	2023-2024	REMAINING
ID#2 DEPARTMENT								
OPERATING REVENUE:								
ANNUAL SEWER SERVICE CHARGE	15,525	15,525	-	46,575	46,575	-	186,300	(139,725)
TOTAL ID #2 REVENUE	15,525	15,525	-	46,575	46,575	-	186,300	(139,725)
OPERATING EXPENSES:								
MONTHLY TREATMENT PLANT COSTS	14,560	14,560	-	39,921	39,921	-	174,720	(134,799)
TOTAL OPERATING COSTS	14,560	14,560	-	39,921	39,921	-	174,720	(134,799)
ADMINISTRATIVE EXPENSES:								
ANNUAL ASSESSMENT PROCESSING	-	-	-	-	-	-	3,000	(3,000)
TOTAL ADMINISTRATIVE EXPENSES	-	-	-	-	-	-	3,000	(3,000)
TOTAL ID#2 EXPENSES	14,560	14,560	-	39,921	39,921	-	177,720	(137,799)
NET OPERATING REVENUE/EXPENSE	965	965	-	6,654	6,654	-	8,580	(1,926)
NON-OPERATING SOURCE OF FUNDS:								
INTEREST INCOME/UNREALIZED GAIN ON INV	880	670	210	5,077	2,010	3,067	8,040	(2,963)
TOTAL NON-OPER SOURCE OF FUNDS	880	670	210	5,077	2,010	3,067	8,040	(2,963)
TOTAL REVENUE/EXPENSE	1,845	1,635	210	11,731	8,664	3,067	16,620	(4,889)
TRANSFER TO SINKING FUND FOR CAPACITY				11,731				
				-				
ID #2 FUND BALANCE:								
ENDING FUNDS AVAILABLE 2021-2022	358,096							
SINKING FUND FOR CAPACITY	11,731							
TOTAL FUNDS AVAILABLE	369,827							

**TEMESCAL VALLEY WATER DISTRICT
REVENUE AND EXPENDITURE/BUDGET
FOR TWO MONTHS ENDING
AUGUST 31, 2023**

REVISED

	SEPTEMBER			YEAR TO DATE			BUDGET	BUDGET
	ACTUAL	BUDGET	VARIANCE	ACTUAL	BUDGET	VARIANCE	2023-2024	REMAINING
<i>NON-POTABLE WATER DEPARTMENT</i>								
OPERATING REVENUE:								
RECYCLED/NON-POTABLE WATER SALES	165,375	210,000	(44,625)	610,639	666,000	(55,361)	2,100,000	(1,489,361)
RECYCLED/ NON-POT WATER FIXED CHARGE	26,312	25,000	1,312	79,050	75,000	4,050	300,000	(220,950)
RECYCLED/NON-POTABLE PUMPING CHARGE	6,984	8,400	(1,416)	23,963	26,600	(2,637)	84,000	(60,037)
MISC INCOME	-	850	(850)	2,723	2,550	173	10,000	(7,277)
INSPECTION REVENUE	2,826	1,800	1,026	4,194	5,400	(1,206)	22,000	(17,806)
TOTAL NON-POTABLE REVENUE	201,497	246,050	(44,553)	720,569	775,550	(54,981)	2,516,000	(1,795,431)
OPERATING EXPENSES:								
WAGES EXPENSE-OPERATIONS	15,216	14,700	516	35,309	34,300	1,009	127,000	(91,691)
WAGES EXPENSE-INSPECTION	3,116	3,000	116	7,230	7,000	230	26,000	(18,770)
PAYROLL TAXES EXP	289	350	(61)	478	810	(332)	3,000	(2,522)
EMPLOYEE BENEFITS-INS	709	1,350	(641)	1,470	4,050	(2,580)	16,000	(14,530)
EMPLOYEE BENEFITS-RETIREMENT	1,529	2,800	(1,271)	4,587	6,500	(1,913)	24,000	(19,413)
MILEAGE EXP	-	100	(100)	-	300	(300)	1,000	(1,000)
OVERTIME EXP	1,441	1,000	441	2,722	2,400	322	9,000	(6,278)
OVERTIME EXP INSPECTION	-	250	(250)	477	550	(73)	2,000	(1,523)
OVERTIME CROSS CONNECTION	-	1,250	(1,250)	-	3,750	(3,750)	15,000	(15,000)
VACATION EXP	980	1,000	(20)	2,793	3,000	(207)	12,000	(9,207)
PLAN CHECK EXP (TVWD)	-	100	(100)	-	300	(300)	1,000	(1,000)
SCADA SYSTEM STANDBY EXP	-	300	(300)	-	700	(700)	2,600	(2,600)
SCADA SYS MAINTENANCE EXP	-	450	(450)	-	1,350	(1,350)	5,000	(5,000)
LABORATORY TESTING COSTS	-	500	(500)	635	2,300	(1,665)	10,000	(9,365)
EQUIPMENT REPAIRS & MAINT.	11,278	10,500	778	19,447	17,500	1,947	30,000	(10,553)
NONPOTABLE WATER LINE REPAIR	-	2,500	(2,500)	-	7,500	(7,500)	30,000	(30,000)
SECURITY AND ALARM EXP	-	125	(125)	-	375	(375)	1,500	(1,500)
PROPERTY MAINTENANCE	519	2,250	(1,731)	638	6,750	(6,112)	27,000	(26,362)
ENERGY COSTS	40,032	33,500	6,532	129,673	106,200	23,473	335,000	(205,327)
CONSUMABLE SUPPLIES EXP	208	125	83	208	375	(167)	1,500	(1,292)
CHEMICALS, LUBRICANTS & FUELS	209	500	(291)	1,074	1,500	(426)	5,000	(3,926)
PERMITS AND FEES EXP	1,434	1,000	434	2,071	3,000	(929)	10,000	(7,929)
SERVICE METERS AND PARTS COSTS	-	600	(600)	-	1,800	(1,800)	7,000	(7,000)
RECYCLED SIGN/TOOLS EXP	-	350	(350)	-	1,050	(1,050)	4,000	(4,000)
MISC OPERATING EXP	-	-	-	-	-	-	500	(500)
BAD DEBT	-	-	-	-	-	-	2,000	(2,000)
CONTINGENCIES	-	2,310	(2,310)	-	6,930	(6,930)	27,705	(27,705)
TOTAL OPERATING EXPENSES	76,960	80,910	(3,950)	208,812	220,290	(11,478)	734,805	(525,993)

**TEMESCAL VALLEY WATER DISTRICT
REVENUE AND EXPENDITURE/BUDGET
FOR TWO MONTHS ENDING
AUGUST 31, 2023**

REVISED

	SEPTEMBER			YEAR TO DATE			BUDGET	BUDGET
	ACTUAL	BUDGET	VARIANCE	ACTUAL	BUDGET	VARIANCE	2023-2024	REMAINING
ADMINISTRATIVE EXPENSES:								
CONTRACT MANAGEMENT	6,239	6,200	39	16,521	18,600	(2,079)	74,000	(57,479)
GENERAL ENGINEERING	1,776	1,000	776	1,879	3,000	(1,121)	10,000	(8,121)
EMPLOYEE BENEFITS-INS	1,141	1,200	(59)	2,606	3,600	(994)	14,000	(11,394)
EMPLOYEE BENEFITS-RETIREMENT	1,640	2,750	(1,110)	4,920	6,450	(1,530)	24,000	(19,080)
WAGES EXPENSE	14,904	15,000	(96)	36,209	37,800	(1,591)	148,000	(111,791)
VACATION EXP	822	825	(3)	2,466	2,475	(9)	9,900	(7,434)
MILEAGE EXP	-	-	-	-	-	-	200	(200)
OVERTIME EXP	-	150	(150)	106	450	(344)	1,500	(1,394)
PAYROLL TAX EXPENSE	225	260	(35)	533	620	(87)	2,300	(1,767)
CONTRACT STAFFING OFFICE EXP	-	-	-	-	-	-	2,500	(2,500)
LEGAL EXPENSE	447	600	(153)	1,678	1,800	(122)	7,000	(5,322)
AUDIT EXP	-	-	-	-	-	-	4,900	(4,900)
BOARD FEES EXP	300	750	(450)	1,078	2,250	(1,172)	9,000	(7,922)
ELECTION & PUBLIC HEARING EXP	-	-	-	-	-	-	7,500	(7,500)
COMPUTER SYSTEMS EXP	4,619	4,000	619	8,101	8,000	101	28,000	(19,899)
BANK CHARGES	1,953	2,100	(147)	5,911	6,300	(389)	25,000	(19,089)
MISC & EDUCATION EXP	-	250	(250)	-	250	(250)	1,000	(1,000)
TELEPHONE EXP	1,200	1,000	200	2,631	3,000	(369)	12,000	(9,369)
OFFICE SUPPLIES	424	1,000	(576)	1,946	3,000	(1,054)	12,000	(10,054)
PRINTING EXP	-	650	(650)	2,774	1,950	824	8,000	(5,226)
POSTAGE EXP	745	650	95	2,155	1,950	205	8,000	(5,845)
PUBLICATION/DUES EXP	-	250	(250)	-	750	(750)	3,000	(3,000)
EQUIPMENT LEASE EXP	619	390	229	1,258	1,170	88	4,700	(3,442)
INSURANCE EXPENSE	2,338	2,500	(162)	6,675	7,500	(825)	30,000	(23,325)
ANNUAL ASSESSMENT EXP	-	250	(250)	-	750	(750)	3,000	(3,000)
INVESTMENT EXPENSE	500	300	200	1,498	900	598	3,500	(2,002)
COMMUNITY OUTREACH EXP	-	5,000	(5,000)	3,772	5,000	(1,228)	5,000	(1,228)
TOTAL ADMINISTRATIVE EXPENSES	<u>39,892</u>	<u>47,075</u>	<u>(7,183)</u>	<u>104,717</u>	<u>117,565</u>	<u>(12,848)</u>	<u>458,000</u>	<u>(353,283)</u>
TOTAL NON-POTABLE OPERATING EXPENSES	<u>116,852</u>	<u>127,985</u>	<u>(11,133)</u>	<u>313,529</u>	<u>337,855</u>	<u>(24,326)</u>	<u>1,192,805</u>	<u>(879,276)</u>
NET OPERATING REVENUE/EXPENSE	<u>84,645</u>	<u>118,065</u>	<u>(33,420)</u>	<u>407,040</u>	<u>437,895</u>	<u>(30,655)</u>	<u>1,323,195</u>	<u>(916,155)</u>
NON-OPERATING SOURCE OF FUNDS:								
INTEREST INCOME	4,843	1,000	3,843	27,942	3,000	24,942	12,000	15,942
TOTAL NON-OP SOURCE OF FUNDS	<u>4,843</u>	<u>1,000</u>	<u>(29,577)</u>	<u>27,942</u>	<u>3,000</u>	<u>24,942</u>	<u>12,000</u>	<u>15,942</u>
TOTAL REVENUE/EXPENSE	<u>89,488</u>	<u>119,065</u>	<u>(29,577)</u>	<u>434,982</u>	<u>440,895</u>	<u>(5,713)</u>	<u>1,335,195</u>	<u>(900,213)</u>
TRANSFER TO CAPITAL FUND-REPLACEMENT				88,049				
TRANSFER TO CAPITAL FUND-IMPROVEMENT				346,933				
CONNECTION FEES				-				
				-				
NON-POTABLE FUND BALANCE:								
ENDING FUNDS AVAILABLE 2021-2022	7,109,034							
TRANSFER FOR CAPITAL FUND REPLACEMENT	88,049							
TRANSFER FOR CAPITAL IMPROVEMENTS	346,933							
CAPITAL IMPROVEMENT (SEE ATTACHED DETAIL)	(24,746)							
TOTAL FUNDS AVAILABLE	<u>7,519,270</u>							

**TEMESCAL VALLEY WATER DISTRICT
General Ledger**

For the Period From Jul 1, 2023 to Sep 30, 2023

Filter Criteria includes: 1) IDs from 567500.3 to 567500.5. Report order is by ID. Report is printed with Hide Period Subtotals on Multi-Period Report and in Detail Format.

Account ID Account Description	Date	Reference	Jrn	Trans Description	Debit Amt	Credit Amt	Balance
567500.3	7/1/23			Beginning Balance			
EQUIPMENT REPAIRS & MAIN	7/11/23	2744	PJ	PARRA LANDSCAPE MAINTENANCE	403.75		
	7/11/23	2742	PJ	PARRA LANDSCAPE MAINTENANCE	130.00		
	7/20/23	258253	PJ	NORTHSTAR CHEMICAL - Replacemtn float for level indicator for twwd	113.14		
	7/20/23	10628	PJ	CENTER ELECTRIC SERVICES INC. - INSTALL NEW RECEPТА CLEONNECTIONS AND NEW ETHERNET CABLES FOR PAUL AND KIMS COMPUTERS	865.99		
	7/26/23	5289-E	PJ	GMC ELECTRICAL INC - Annual cathodic protection system service agreement for years 2023-2024	1,380.00		
	7/26/23	33364	PJ	MASTER TECH MECHANICAL - CLEANED CONDENSER FOR SBR BLDG AC/UNIT	189.00		
	7/26/23	33042	PJ	MASTER TECH MECHANICAL - ADMIN CONFERENCE ROOM HVAC	109.00		
	7/27/23	28709	CD	JUAN TORRES - EQUIPMENT REPAIRS & MAINT.	56.00		
	7/27/23	7/28/2023	PJ	HOME DEPOT CREDIT SERVICES	133.81		
	7/27/23	7/28/2023	PJ	HOME DEPOT CREDIT SERVICES	217.46		
	7/27/23	7/28/2023	PJ	HOME DEPOT CREDIT SERVICES	102.14		
	7/27/23	7/28/2023	PJ	HOME DEPOT CREDIT SERVICES	12.50		
	7/27/23	602942/1	PJ	MCFADDEN-DALE HARDWARE CO.	187.03		
	7/27/23	602974/1	PJ	MCFADDEN-DALE HARDWARE CO.	120.36		
	8/1/23	20944	PJ	DOUGLAS ENVIRONMENTAL GROUP - CALIBRATE WASTEWATER MONITORING METERS	4,100.00		
	8/18/23	21384594	PJ	RT OLSON PLUMBING - FRIDAY INSPECTION AND LEAK DETECTION, MAIN LINE REBUILD WITH PIGTAILS TO ISOLATE ADMIN AND OPERATIONS BLDG	5,440.00		
	8/18/23	260985-ST	PJ	BAY CITY INDUSTRIAL SUPPLY - 260618 SALES TAX	3,636.04		
	8/18/23	260985-ST	PJ	BAY CITY INDUSTRIAL SUPPLY - 260985 SALES TAX	1,385.34		
	8/23/23	2253	PJ	DRY COUNTY RESTORATION	10,253.14		
	8/23/23	53882999	PJ	DXP CORTECH - Trouble shoot sewage pumps 2 tech @ 6 hours	1,980.00		
	8/23/23	592-1	PJ	GJR ELECTRIC - REMOVE REPAIR AND REPLACE VFD ENCLOSURE AT THE POND PER QUOTE DATED 04/25/2023	4,818.00		
	8/24/23	28828	CD	JUAN TORROS - EQUIPMENT REPAIRS & MAINT.	70.00		
	8/30/23	02773	PJ	PARRA LANDSCAPE MAINTENANCE	95.50		
	8/30/23	02768	PJ	PARRA LANDSCAPE MAINTENANCE	475.00		
	8/30/23	I2023-1161	PJ	D&H WATER SYSTEMS - A3-QN66 TUBE ASSY FOR M3 CL2 PUMPS	1,062.08		
	8/31/23	08222023	PJ	US BANK GOVERNMENT SERVICES	20.80		
	9/1/23	28838	PR	MEL E. McCULLOUGH	38.02		
	9/1/23	28839	PR	PAUL F. BISHOP	30.00		
	9/1/23	10611	PJ	TRAN CONTROLS SCADA SOLUTIONS, - QUOTE 168	750.00		
	9/1/23	3984	PJ	BT PIPELINE INC. - FIX 1" PVC LINE IN THE ASPHALT AT RETREAT SEWER LIFT STATION	1,500.00		
	9/1/23	53936597	PJ	DXP CORTECH - REMOVE & INSTALL SLUDGE PUMP AT DIGESTER	2,640.00		
	9/1/23	1417	PJ	ON POWER INDUSTRIES - SEMI ANNUAL LEVEL 1 + LEVEL 2 DISTRICT GENERATOR FLEET PREVENTATIVE MAINTENANCE	3,124.00		
	9/13/23	33265	PJ	MASTER TECH MECHANICAL - QUARTERLY HVAC MAINTENANCE FULL VISIT WITH CHEMICAL CLEANINGS	726.25		

TEMESCAL VALLEY WATER DISTRICT

General Ledger

For the Period From Jul 1, 2023 to Sep 30, 2023

Filter Criteria includes: 1) IDs from 567500.3 to 567500.5. Report order is by ID. Report is printed with Hide Period Subtotals on Multi-Period Report and in Detail Format.

Account ID Account Description	Date	Reference	Jrn	Trans Description	Debit Amt	Credit Amt	Balance
	9/13/23	I2023-1291	PJ	D&H WATER SYSTEMS - Replacedment air filters for mixer panels @ reservoirs	68.49		
	9/22/23	28900	CD	JUAN TORRES - EQUIPMENT REPAIRS & MAINT.	105.00		
	9/28/23	10677	PJ	CENTER ELECTRIC SERVICES INC. - DISCONNECT POLYMER PUMP IN CENT BUILDING	260.14		
	9/28/23	33238	PJ	MASTER TECH MECHANICAL - CHECK + BOTH AC UNITS ON RECLAIM PUMP ROOM REPLACE COMPRESSOR CONTROL MODULE	743.36		
	9/28/23	608045/1	PJ	MCFADDEN-DALE HARDWARE CO.	1,098.58		
	9/28/23	9/28/2023	PJ	HOME DEPOT CREDIT SERVICES	19.88		
	9/28/23	9/28/2023	PJ	HOME DEPOT CREDIT SERVICES	384.19		
	9/28/23	9/28/2023	PJ	HOME DEPOT CREDIT SERVICES	263.52		
				Change	49,107.51		49,107.51
	9/30/23			Ending Balance			49,107.51
567500.4 EQUIPMENT REPAIRS & MAIN	7/1/23			Beginning Balance			
	7/11/23	30311	PJ	TERRY'S MINUTE VALVE SERVICE - CLA-VAL SERVICE SYCAMORE & TRILOGY RECLAIM	600.00		
	7/11/23	INV2023-39	PJ	DON PETERSON CONTRACTING, INC. - TRILOGY-PUMP #3 REMOVE AND REPLACE	4,145.00		
	7/13/23	7/12/2023	PJ	BT PIPELINE INC. - 8825 Cuyamaca St replace meter box and meter setter	1,797.00		
	7/13/23	7/21/2023	PJ	BT PIPELINE INC. - FIRE HYDRANT REPAIR 10825 ROSEMARY RESET AIR VAC AND PAD DOS LAGO	1,424.00		
	7/13/23	7/6/2023	PJ	BT PIPELINE INC. - 8791 LUXURY CT FIX WATER LEAK ON COPPER AND REPLACE CHECK VALVE	1,424.00		
	7/13/23	7/27/2023	PJ	BT PIPELINE INC. - FIX LEAK ON 23247 CAMINO TERRAZA RD	1,719.00		
	7/13/23	7/18/2023	PJ	BT PIPELINE INC. - REPAIR WATER SERVICE LEAK 9081 EVONVALE DR	1,547.00		
	7/13/23	7/19/2023	PJ	BT PIPELINE INC. - PAVE STRET WATER SERVICE REPAIR	1,547.00		
	7/18/23	062223	PJ	US BANK GOVERNMENT SERVICES	209.99		
	7/26/23	5289-E	PJ	GMC ELECTRICAL INC	1,207.50		
	7/27/23	28709	CD	JUAN TORRES - EQUIPMENT REPAIRS & MAINT.	49.00		
	8/24/23	28828	CD	JUAN TORROS - EQUIPMENT REPAIRS & MAINT.	70.00		
	8/30/23	1035	PJ	VALLEY CITIES/GONZALES FENCE - REPAIR DOWN FENCE AT WILDROSE TANK	2,000.00		
	8/30/23	1034	PJ	VALLEY CITIES/GONZALES FENCE - REPAIR DOWN FENCE AT WILDROSE TANK	950.00		
	9/1/23	3985	PJ	BT PIPELINE INC. - 22577 SILVER DOLLAR PLUMBER CUT OUT PART OF METER SETTER DOING REPAIRS FOR HOME OWNER	2,000.00		
	9/1/23	3986	PJ	BT PIPELINE INC. - 23024 SUNROSE AND CARLOS METER SETTER REPAIR LEAKING METER SETTER	2,000.00		
	9/1/23	1417	PJ	ON POWER INDUSTRIES	2,773.50		
	9/12/23	33227	PJ	MASTER TECH MECHANICAL - Diagnostic fee for sycamore potable booster	109.00		
	9/13/23	33265	PJ	MASTER TECH MECHANICAL	726.25		
	9/13/23	INV2023-56	PJ	DON PETERSON CONTRACTING, INC. - TRILOGY PUMP STATION	4,520.00		
	9/22/23	28900	CD	JUAN TORRES - EQUIPMENT REPAIRS & MAINT.	105.00		

TEMESCAL VALLEY WATER DISTRICT
General Ledger
For the Period From Jul 1, 2023 to Sep 30, 2023

Filter Criteria includes: 1) IDs from 567500.3 to 567500.5. Report order is by ID. Report is printed with Hide Period Subtotals on Multi-Period Report and in Detail Format.

Account ID Account Description	Date	Reference	Jrn	Trans Description	Debit Amt	Credit Amt	Balance
567500.4 (cont.)				MAINT. Change			
	9/30/23			Ending Balance	30,923.24		30,923.24
567500.5	7/1/23			Beginning Balance			
EQUIPMENT REPAIRS & MAIN	7/26/23	5289-E	PJ	GMC ELECTRICAL INC	862.50		
	7/27/23	28709	CD	JUAN TORRES - EQUIPMENT REPAIRS & MAINT.	35.00		
	8/15/23	43131	PJ	MORR-IS TESTED IN - JET TRAILER FOR AG LINE ON GOLD COURSE	980.00		
	8/23/23	33237	PJ	MASTER TECH MECHANICAL - REPAIR PLC CABINET AC UNIT SYC RW BOOSTER	6,291.80		
	9/1/23	1417	PJ	ON POWER INDUSTRIES	1,912.50		
	9/11/23	33432	PJ	MASTER TECH MECHANICAL - Well 1A CABINET A/C UNIT REBUILD	3,035.14		
	9/28/23	10676	PJ	CENTER ELECTRIC SERVICES INC. - TROUBLE SHOOT SYC RW BOOSTER PUMP #4 VFD	6,330.19		
				Change			
	9/30/23			Ending Balance	19,447.13		19,447.13

TEMESCAL VALLEY WATER DISTRICT
Community Facilities District No. 1
Financing Authority
(Sycamore Creek)
9/30/2023

<u>Special Tax Fund (Acct #105636-009)</u> Account Balance at Wilmington Trust	\$ 20,295.20
<hr/>	
<u>BONDS PR ACCT (Acct # 105636-010)</u> Account Balance at Wilmington Trust	0.88
<hr/>	
<u>Administrative Expense Fund(Acct #105636-011)</u> Account Balance at Wilmington Trust	9.23
<hr/>	
<u>Surplus Fund (Acct #105636-012)</u> Account Balance at Wilmington Trust	1,231,516.51
<hr/>	

TEMESCAL VALLEY WATER DISTRICT
Community Facilities District No. 2
Financing Authority
(Montecito Ranch)
9/30/2023

<u>Special Tax Fund (Acct #105636-014)</u> Account Balance at Wilmington Trust	\$ 8,794.55
<hr/>	
<u>BONDS PR ACCT (Acct # 105636-015)</u> Account Balance at Wilmington Trust	0.12
<hr/>	
<u>Administrative Expense Fund(Acct #105636-016)</u> Account Balance at Wilmington Trust	5.22
<hr/>	
<u>Surplus Fund (Acct #105636-017)</u> Account Balance at Wilmington Trust	257,684.97
<hr/>	
<u>Prepayment Fund (Acct #105636-026)</u> Account Balance at Wilmington Trust	-
<hr/>	
TOTAL	\$ 266,484.86

TEMESCAL VALLEY WATER DISTRICT
Community Facilities District No. 3
Financing Authority
(The Retreat)
9/30/2023

<u>Special Tax Fund (Acct #105636-019)</u> Account Balance at Wilmington Trust	\$	8,581.72
<hr/>		
<u>BONDS PR ACCT (Acct # 105636-020)</u> Account Balance at Wilmington Trust	\$	0.68
<hr/>		
<u>Administrative Expense Fund(Acct #105636-021)</u> Account Balance at Wilmington Trust	\$	9.23
<hr/>		
<u>Surplus Fund (Acct #105636-022)</u> Account Balance at Wilmington Trust	\$	654,704.80
<hr/>		
Prepayment Fund (Acct #105636-027) Account Balance at Wilmington Trust		-
<hr/>		
TOTAL	\$	663,296.43

TEMESCAL VALLEY WATER DISTRICT
Community Facilities District
Financing Authority
9/30/2023

Senior Lien Bonds - Revenue Fund (Acct #105636-000)	\$	0.03
- Lien Interest A/C (Acct #105636-001)		16,267.22
- Lien Principal A/C (Acct #105636-002)		-
- Financing Authority Surplus A/C (Acct #105636-003)		-
- Reserve Fund CFD #1 (Acct #105636-004)		2,274,147.32
- Reserve Fund CFD #2 (Acct #105636-005)		277,115.19
- Reserve Fund CFD #3 (Acct #105636-006)		1,501,203.78
Junior Lien Bonds - Revenue Fund (Acct #105639-000)	\$	-
- Lien Interest A/C (Acct #105639-001)		5,077.35
- Lien Principal A/C (Acct #105639-002)		-
- Financing Authority Surplus A/C (Acct #105639-003)		-
- Reserve Fund CFD #1 (Acct #105639-004)		621,400.71
- Reserve Fund CFD #2 (Acct #105639-005)		100,555.25
- Reserve Fund CFD #3 (Acct #105639-006)		542,917.23
TOTAL		
	\$	5,338,684.08

TEMESCAL VALLEY WATER DISTRICT
Community Facilities District No. 4 IA1
Financing Authority
(Terramor)
9/30/2023

<u>Special Tax Fund Proceeds (Acct #133306-000)</u> Account Balance at Wilmington Trust	\$ -
<hr/>	
<u>Special Tax Fund (Acct #133306-001)</u> Account Balance at Wilmington Trust	\$ 210,440.76
<hr/>	
<u>Interest Acct (Acct #133306-002)</u> Account Balance at Wilmington Trust	469.48
<hr/>	
<u>BONDS PR ACCT (Acct #133306-003)</u> Account Balance at Wilmington Trust	470.73
<hr/>	
<u>Administrative Expense Fund(Acct #133306-004)</u> Account Balance at Wilmington Trust	48,286.22
<hr/>	
<u>Reserve fund Fund (Acct #133306-005)</u> Account Balance at Wilmington Trust	1,408,906.93
<hr/>	-
<u>Surplus Fund (Acct #133306-006)</u> Account Balance at Wilmington Trust	229,135.25
<hr/>	
<u>Redemption fund (Acct #133306-007)</u> Account Balance at Wilmington Trust	-
<hr/>	
<u>Construction fund (Acct #133306-008)</u> Account Balance at Wilmington Trust	0.82
<hr/>	
<u>Cost of Issuance (Acct #133306-009)</u> Account Balance at Wilmington Trust	-
<hr/>	
TOTAL	\$ 1,897,710.19

TEMESCAL VALLEY WATER DISTRICT
Community Facilities District No. 4 IA2
Financing Authority
(Terramor)
9/30/2023

Special Tax Fund (Acct #151110-000)
Account Balance at Wilmington Trust \$ 155,741.11

Interest Acct (Acct #151110-001)
Account Balance at Wilmington Trust 343.76

BONDS PRIN ACCT (Acct #151110-002)
Account Balance at Wilmington Trust 41.62

Redemption Acct (Acct #151110-003)
Account Balance at Wilmington Trust -

Administrative Expense Fund(Acct #151110-004)
Account Balance at Wilmington Trust -

Reserve fund Fund (Acct #151110-005)
Account Balance at Wilmington Trust 1,140,639.61

Surplus Fund (Acct #151110-006)
Account Balance at Wilmington Trust -

Construction fund (Acct #151110-007)
Account Balance at Wilmington Trust 6,676.51

Cost of Issuance (Acct #151110-008)
Account Balance at Wilmington Trust -

TOTAL \$ 1,303,442.61



PMIA/LAIF Performance Report as of 10/18/23



Quarterly Performance Quarter Ended 09/30/23

LAIF Apportionment Rate ⁽²⁾ :	3.59
LAIF Earnings Ratio ⁽²⁾ :	0.00009812538629360
LAIF Administrative Cost ^{(1)*} :	0.29
LAIF Fair Value Factor ⁽¹⁾ :	0.986307739
PMIA Daily ⁽¹⁾ :	3.48
PMIA Quarter to Date ⁽¹⁾ :	3.42
PMIA Average Life ⁽¹⁾ :	256

PMIA Average Monthly Effective Yields⁽¹⁾

September	3.534
August	3.434
July	3.305**
June	3.167
May	2.993
April	2.870

Pooled Money Investment Account Monthly Portfolio Composition ⁽¹⁾ 09/30/23 \$156.4 billion

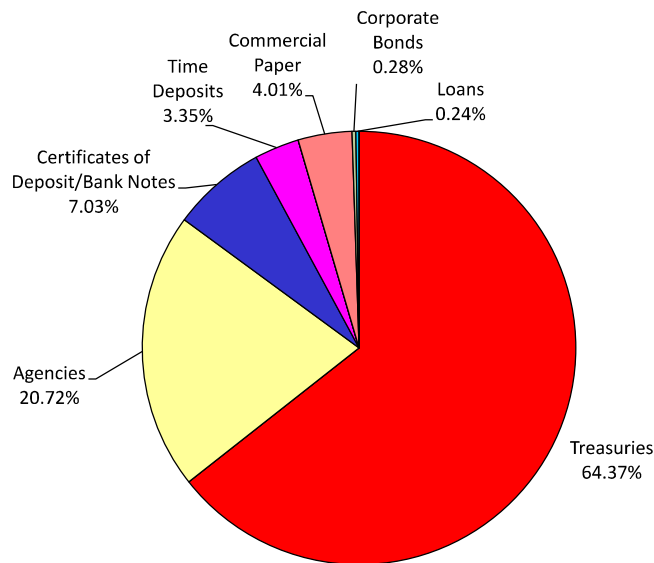

Chart does not include \$2,444,000.00 in mortgages, which equates to 0.002%. Percentages may not total 100% due to rounding.

Daily rates are now available here. [View PMIA Daily Rates](#)

Notes: The apportionment rate includes interest earned on the CalPERS Supplemental Pension Payment pursuant to Government Code 20825 (c)(1) and interest earned on the Wildfire Fund loan pursuant to Public Utility Code 3288 (a).

**The percentage of administrative cost equals the total administrative cost divided by the quarterly interest earnings. The law provides that administrative costs are not to exceed 5% of quarterly EARNINGS of the fund. However, if the 13-week Daily Treasury Bill Rate on the last day of the fiscal year is below 1%, then administrative costs shall not exceed 8% of quarterly EARNINGS of the fund for the subsequent fiscal year.*

** Revised

Source:

⁽¹⁾ State of California, Office of the Treasurer

⁽²⁾ State of California, Office of the Controller

**Temescal Valley Water District
Capital Projects-Budget 2023-2024
Yearly Miscellaneous and Multi - Year**

Not Started
 In Process
 Completed or \$ committed

Capital Projects FY 2023/2024 Maintenance/ General Projects	CIP #	Eng #1401.*	Total Cost	Source of Funding			Previous YR	August 31, 2023			Total YTD	Variance
				Sewer Fund	Water Fund	Recycled Fund		YEAR TO DATE				
				Sewer Fund	Water Fund	Recycled Fund		Sewer Fund	Water Fund	Recycled Fund		
Secondary FEB Pump Replacement	G-5-2021		\$ 120,000	\$ 72,000		\$ 48,000	\$ -			\$ 19,182	19,182	\$ 100,818
GIS Mapping - Water, Sewer, RW pipelines and facilities	G-7-2021	1904/1905	\$ 50,160	\$ 20,064	\$ 17,556	\$ 12,540	\$ 6,700	\$ 16,619	\$ 16,619		33,238	\$ 10,222
Dive and Inspect all Potable Tanks	General		\$ 25,000		\$ 20,000	\$ 5,000	\$ 17,120				-	\$ 7,880
Confined Space and Safety Equipment	General		\$ 12,000	\$ 4,000	\$ 4,000	\$ 4,000	\$ -				-	\$ 12,000
Groundwater Sustainability JPA	General		\$ 135,000	\$ -	\$ 135,000	\$ -	\$ -				-	\$ 135,000
SUBTOTAL			\$ 342,160	\$ 96,064	\$ 176,556	\$ 69,540	\$ 23,820	\$ 16,619	\$ 16,619	\$ 19,182	52,420	\$ 265,920

Multiple Fiscal Year Projects	CIP #	Eng #1401.*	Total Cost	Source of Funding			Previous YR	YEAR TO DATE			Total YTD	Variance
				Sewer Fund	Water Fund	Recycled Fund		YEAR TO DATE				
				Sewer Fund	Water Fund	Recycled Fund		Sewer Fund	Water Fund	Recycled Fund		
Secondary EQ Bypass	S-2023-01		\$ 60,000	\$ 60,000	\$ -	\$ -	\$ -				-	\$ 60,000
Primary EQ Pump Crane	S-2023-02		\$ 70,000	\$ 70,000	\$ -	\$ -	\$ -				-	\$ 70,000
Manhole Rehab	S-2023-03		\$ 526,663	\$ 526,663	\$ -	\$ -	\$ -				-	\$ 526,663
Rehab Well 1A	NP-2023-03		\$ 127,000	\$ -		\$ 127,000	\$ -				-	\$ 127,000
Perk Ponds Expansion and Maintenance	S-2023-04		\$ 73,000	\$ 73,000	\$ -	\$ -	\$ -				-	\$ 73,000
Recycled and Non-potable Pipeline extensions Design	NP-2023-01		\$ 125,000	\$ -	\$ -	\$ 125,000	\$ -				-	\$ 125,000
Recycled and Non-potable Pipeline extensions	NP-2023-01		\$ 875,000	\$ -	\$ -	\$ 875,000	\$ -				-	\$ 875,000
Parking Structure Shades	G-3-2021		\$ 100,000	\$ 40,000	\$ 35,000	\$ 25,000	\$ -				-	\$ 100,000
Convert to Recycled	General		\$ 135,000	\$ -	\$ 75,000	\$ 60,000	\$ 62,564		\$ 7,081	\$ 5,564	12,645	\$ 59,791
New Non-potable Supply Well	NP-2023-02		\$ 305,000	\$ -	\$ -	\$ 305,000	\$ -				-	\$ 305,000
Potable Water from Coldwater Basin	P-2023-01		\$ 1,800,000	\$ -	\$ 1,800,000	\$ -	\$ -				-	\$ 1,800,000
Potable Reservoir Construction	W-2023-02		\$ 4,570,000	\$ -	\$ -	\$ -	\$ -		\$ 53,324		53,324	\$ 4,516,676
Automatic Meter Read System	W-1-2021		\$ 3,050,000	\$ -	\$ 3,050,000	\$ -	\$ -				-	\$ 3,050,000
Sludge Processing Design Report	S-1-2012 A		\$ 80,000	\$ 80,000	\$ -	\$ -	\$ 27,506	\$ 14,868			14,868	\$ 37,626
Sludge Processing Facility with Odor Control	S-1-2021 B		\$ 3,215,000	\$ 3,215,000	\$ -	\$ -	\$ -				-	\$ 3,215,000
Property Purchase and Relocation of Emergency Pump	W-2-2021		\$ 587,000	\$ -	\$ 587,000	\$ -	\$ -				-	\$ 587,000
Reservoir Management System - Terramor Reservoir	W-3-2021		\$ 102,000	\$ -	\$ 102,000	\$ -	\$ -				-	\$ 102,000
Recycled water conversion-approved fy 22-23(WEKA)	NP-2018		\$ 820,000	\$ -	\$ -	\$ 820,000	\$ -				-	\$ 820,000
SUBTOTAL			\$ 16,620,663	\$ 4,064,663	\$ 5,649,000	\$ 2,337,000	\$ 90,070	\$ 14,868	\$ 60,405	\$ 5,564	\$ 80,837	\$ 16,449,756
TOTAL			\$ 16,962,823	\$ 4,160,727	\$ 5,825,556	\$ 2,406,540	\$ 113,890	\$ 31,487	\$ 77,024	\$ 24,746	\$ 133,257	\$ 16,715,676



PORTFOLIO CHARACTERISTICS

Average Modified Duration	1.74
Average Coupon	2.97%
Average Purchase YTM	3.53%
Average Market YTM	5.23%
Average S&P/Moody Rating	AA+/Aa1
Average Final Maturity	1.91 yrs
Average Life	1.84 yrs

ACCOUNT SUMMARY

	Beg. Values as of 8/31/23	End Values as of 9/30/23
Market Value	23,868,827	23,902,843
Accrued Interest	157,790	115,653
Total Market Value	24,026,617	24,018,495
Income Earned	70,233	72,196
Cont/WD		-199
Par	24,686,203	24,783,058
Book Value	24,318,150	24,432,284
Cost Value	24,240,891	24,329,987

TOP ISSUERS

Government of United States	40.0%
Federal Home Loan Bank	18.2%
Federal Farm Credit Bank	12.6%
Federal National Mortgage Assoc	2.6%
Federal Home Loan Mortgage Corp	2.5%
Toyota Motor Corp	1.3%
Paccar Financial	1.2%
Deere & Company	1.2%
Total	79.6%

SECTOR ALLOCATION

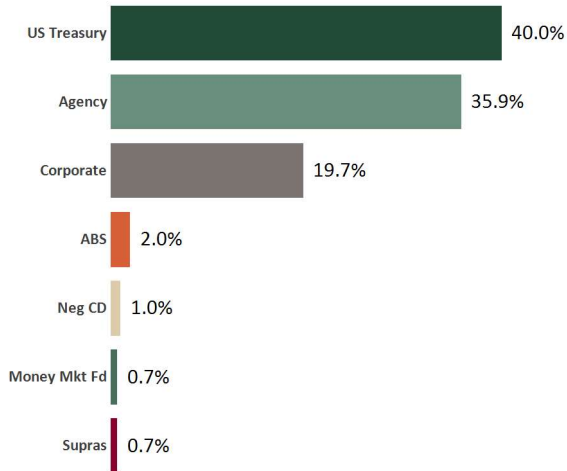

MATURITY DISTRIBUTION

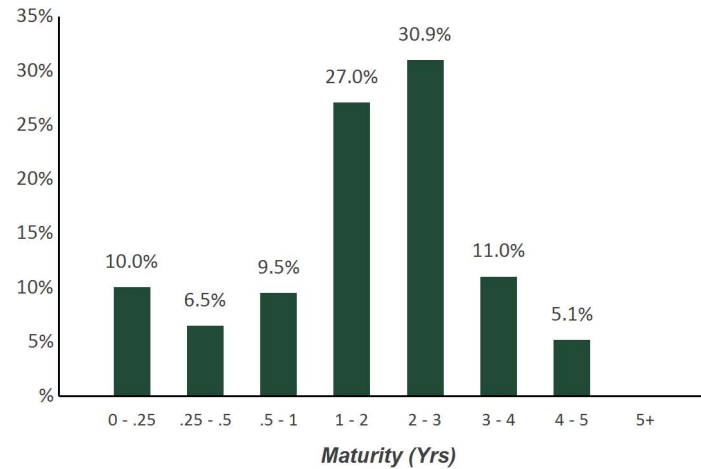

CREDIT QUALITY (S&P)

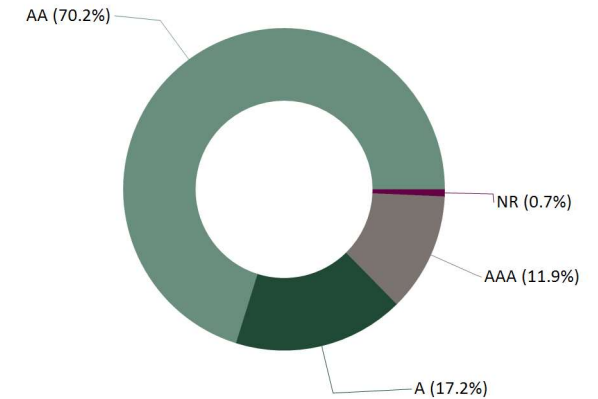

PERFORMANCE REVIEW

TOTAL RATE OF RETURN	Annualized									
	1M	3M	YTD	1YR	2YRS	3YRS	5YRS	10YRS	6/30/2016	
Temescal Valley Water District	-0.03%	0.69%	1.71%	2.57%	-0.93%	-0.57%	1.26%	N/A	1.01%	
ICE BofA 1-3 Yr US Treasury & Agency Index	-0.01%	0.74%	1.74%	2.49%	-1.26%	-0.83%	1.06%	N/A	0.76%	

TEMESCAL VALLEY WATER DISTRICT CUSTOMER COUNT PER YEAR(RESIDENTIAL)

(Excludes SID#1 and SID#2 sewer customers)

DATE	Jul-03	Jul-04	Jul-05	Jul-06	Jul-07	Jul-08	Jul-09	Jul-10	Jul-11	Jul-12	Jul-13	Jul-14	Jul-15	Jul-16	Jul-17	Jul-18	Jul-19	Jul-20	Jul-21	Jul-22	Oct-23
CUSTOMERS	1729	2295	2910	2910	4173	4279	4332	4386	4463	4492	4547	4605	4670	4736	5000	5076	5358	5662	5948	6173	6344

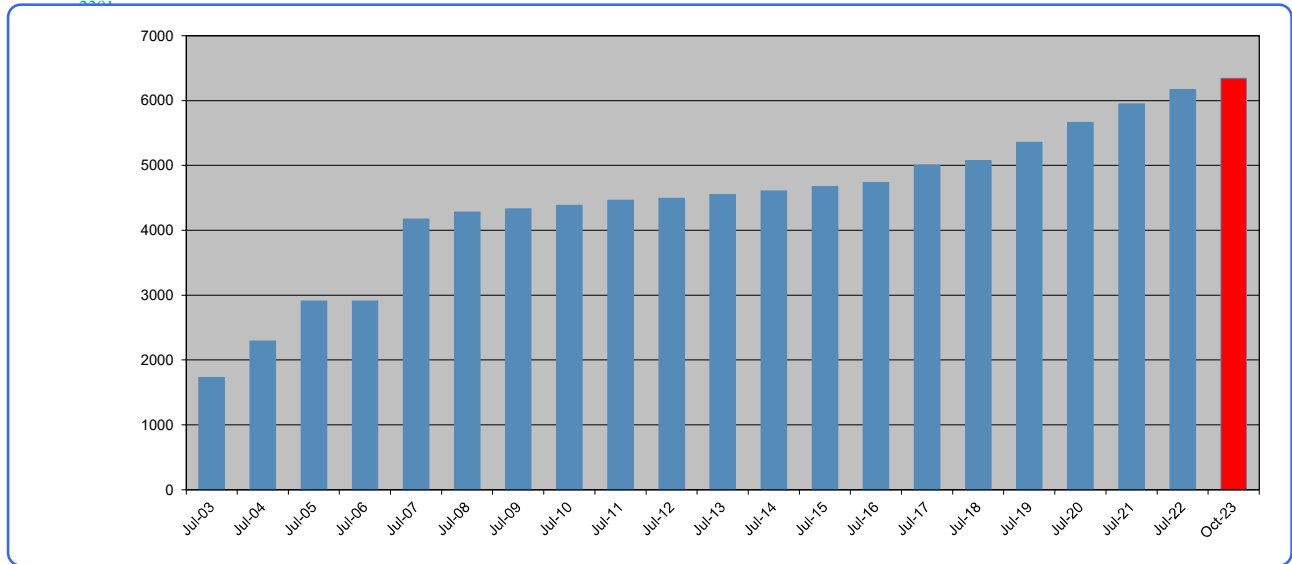

RESIDENTIAL	Total Homes	Completed Homes	
Wildrose Ranch	1043	1043	100%
Trilogy at Glen Ivy	1317	1317	100%
Painted Hills	204	204	100%
Canyon Oaks	26	26	100%
Montecito Ranch	306	306	100%
Sycamore Creek	1735	1735	100%
The Retreat	525	525	100%
Terramor	1487	1127	76% 15 MODELS
Harmony Grove	50	50	100%
Highlands #37155	79	0	0%
Serrano-Taylor Morris	80	11	14%
	6852	6344	93%

TOTAL CUSTOMER COUNT REPORT
9/31/2023

	Water & Sewer	Water Only	Sewer Only	Count
New homes added 5 Accts closed/transf 33 Empty Homes 0			Butterfield (305) Calif. Meadows (345)	
Residential	6332	2	650	6984
Commercial	97	0	2	99
Commercial-fireheld inactive	41			41
Public Govt	4	1	0	5
Irrigation-Industrial	0	68	0	68
Non-Potable Water other	0	161	0	161
Construction-Bulk Sales	0	7	0	7
Total Active Customers	6433	239	652	7365

DELINQUENT REPORT

Meters Read - Customers Billed	6672	
Received Delinquent Notice on current bill	502	
Turned Off for lack of payment	0	0.00%
Customers turned back on, amount paid	0	0.00%

WATER USAGE REPORT FOR THIRTEEN MONTHS

	Sept	Oct	Nov	Dec	Jan	Feb	Mar	Apr	May	June	July	Aug	Sept	TOTAL
Beg Water Levels	13283	13570	12382	13811	13005	12295	13482	13208	12935	13103	12219	12753	12857	
Ending Water Levels	2381	12382	13811	13005	12295	13482	13208	12935	13103	12219	12753	12857	12822	
Cur Yearly Purchases	136388	122599	102998	86901	83066	92611	59585	107860	116585	117904	144841	153211	133178	1457727
Cur Yr Monthly Use	127809	117899	92414	83718	78318	89669	54981	100480	106763	110202	136178	144915	123547	1366893
Prior Yr Monthly Use	142826	116129	104291	92551	85242	114797	101282	132069	126528	139475	175991	143103	127809	1602093

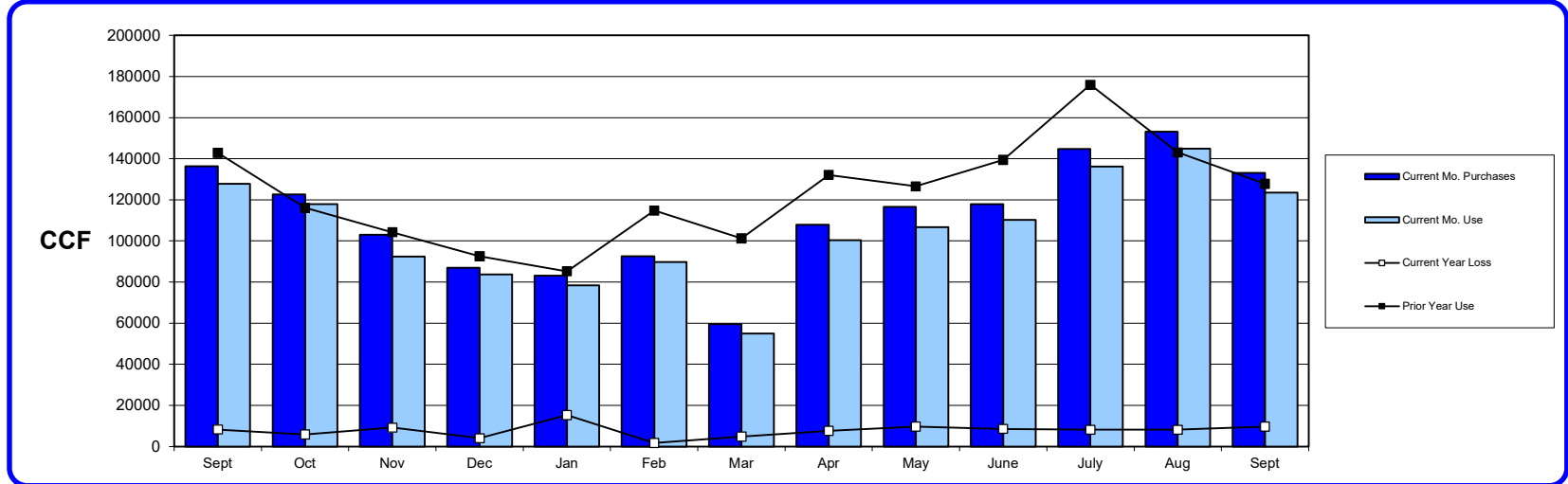

KEY

2021-2022
2022-2023
2023-2024

SUMMARY

Beginning Water in System	13283 CCF
Water Purchased in last 13 months	1457727 CCF
Water Used in last 13 months	1366893 CCF
Water Remaining in System	12822 CCF
(Loss)/Gain over last 13 months	(91295) CCF

-6.26%

RESIDENTIAL WATER USAGE AVERAGE DAILY FLOW

	Sept	Oct	Nov	Dec	Jan	Feb	Mar	Apr	May	June	July	Aug	Sept	YEARLY AVERAGE
Average Daily Flow	450	359	397	301	234	265	188	373	352	405	482	510	439	359
Prior Yr Average Daily Flow	508	432	357	368	261	337	373	373	453	487	498	495	450	407

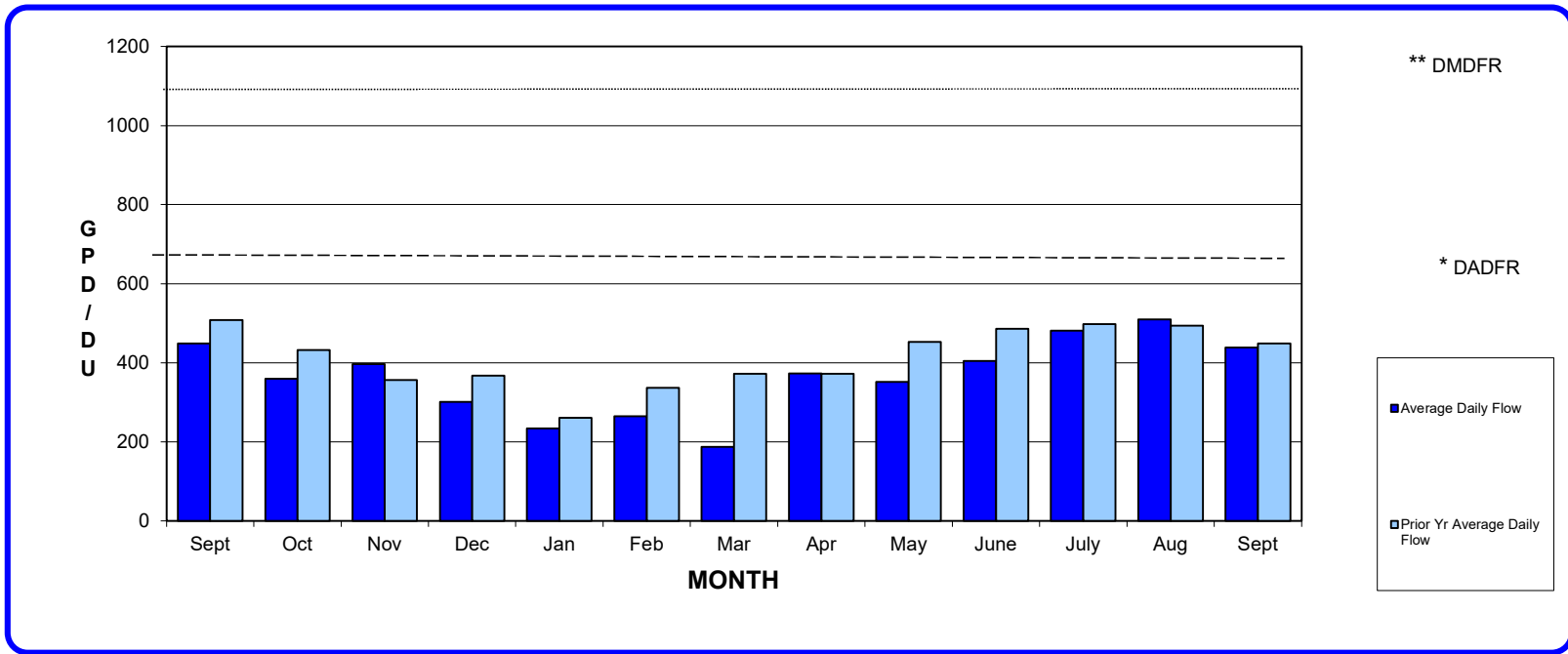

Key
2021-2022
2022-2023
2023-2024

- * DESIGN AVERAGE DAILY FLOW RATE IN GPD (650)
- ** DESIGN MAXIMUM DAILY FLOW RATE IN GPD (1140)

**Temescal Valley Water District
Volume of Water Sold
For Three Month Ending September 30, 2023
F/Y 2023-2024**

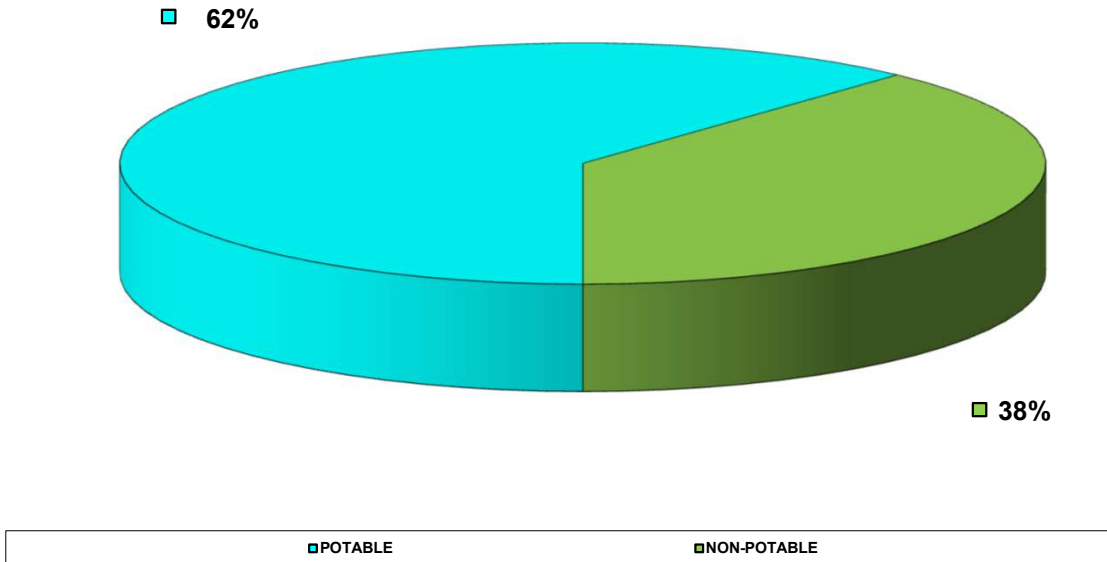

**Temescal Valley Water District
Water Volume Sold
For F/Y 2022-2023
Twelve Months**

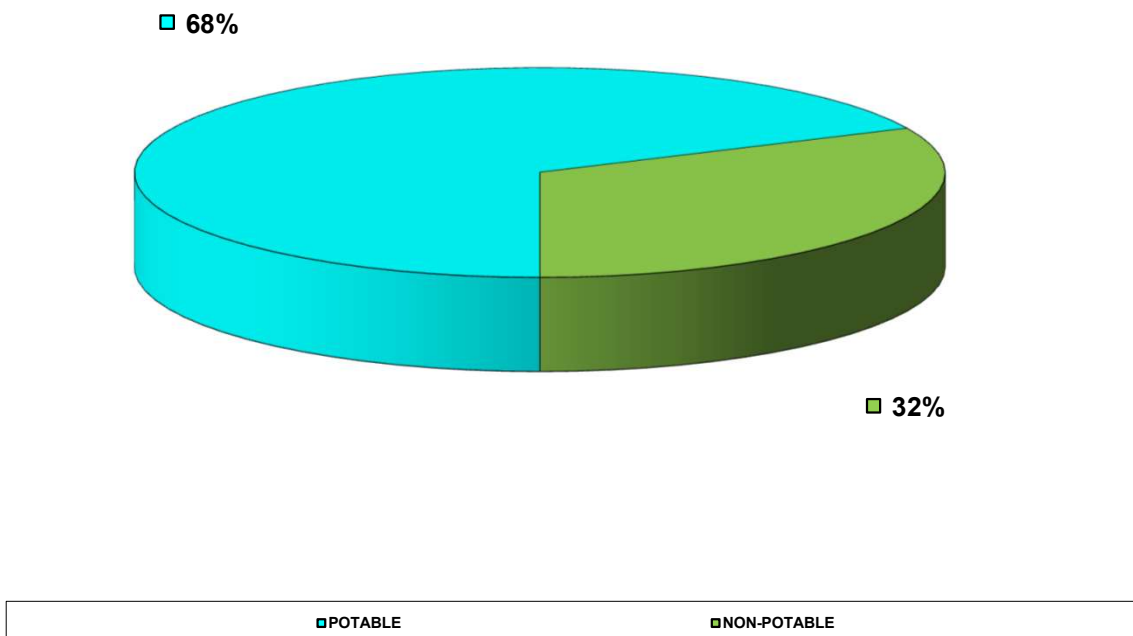

COMMERCIAL WATER USAGE AVERAGE DAILY FLOW

	Sept	Oct	Nov	Dec	Jan	Feb	Mar	Apr	May	June	July	Aug	Sept	YEARLY AVERAGE
Average Daily Flow	771	639	723	757	640	823	885	839	726	679	677	711	696	733
Prior Yr Average Daily Flow	838	721	744	684	625	675	577	704	688	827	683	632	771	694

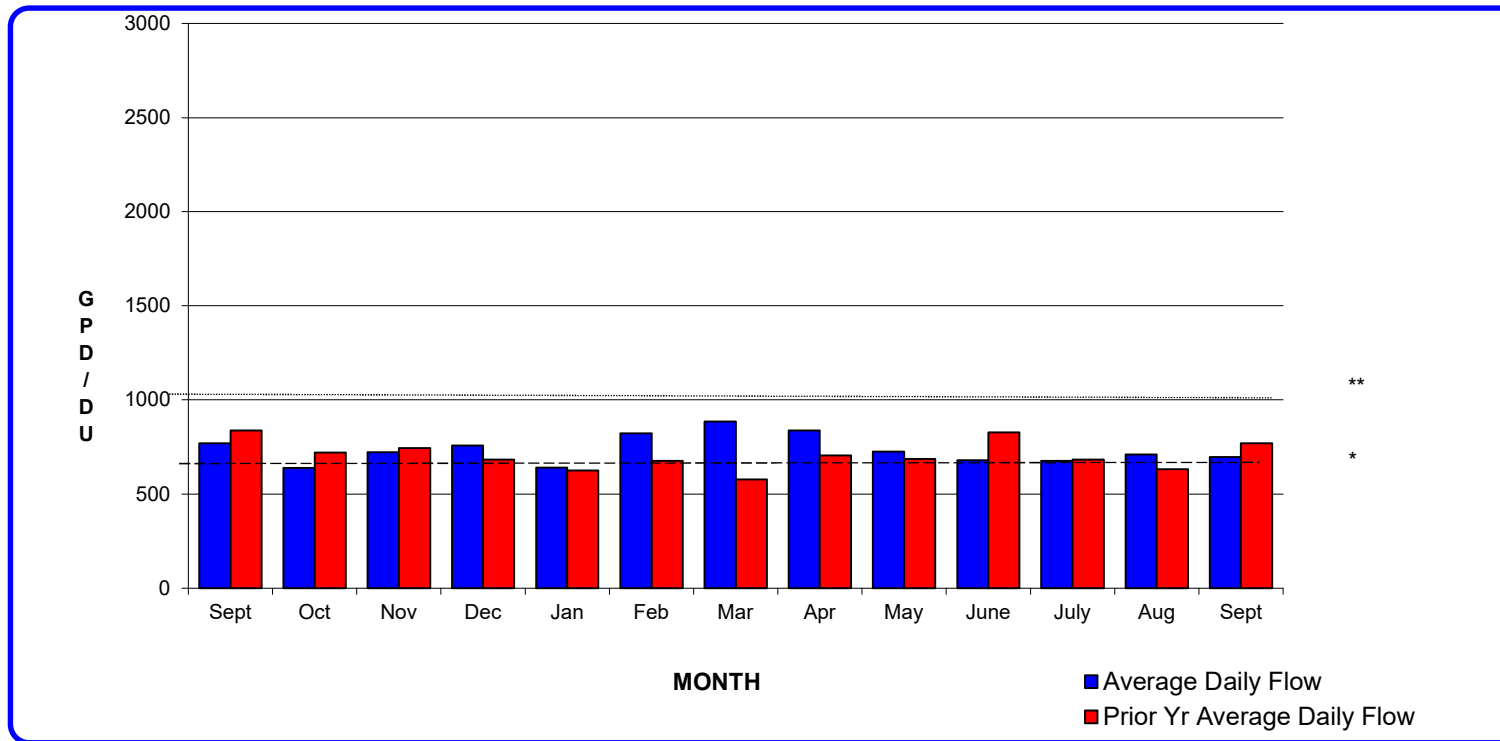

Key
2021-2022
2022-2023
2023-2024

* DESIGN AVERAGE DAILY FLOW RATE IN GPD (650)

** DESIGN MAXIMUM DAILY FLOW RATE IN GPD (1140)

RECYCLED AND NON-POTABLE WELL WATER MONTHLY FLOW (ccf)

	Sept	Oct	Nov	Dec	Jan	Feb	Mar	Apr	May	June	July	Aug	Sept
Current Yr Use	78606.00	72199.40	45087.97	33349.86	10641.96	23851.67	5289.99	38690.00	61224.44	56587.53	94916.80	93141.21	67397.96
Prior Yr Use	92269.57	66474.53	58720.00	37812.00	23570.72	42797.73	38517.00	72833.55	74866.40	70903.37	107422.03	84406.00	78606.00
Revenue	\$222,455	\$204,324	\$127,598	\$94,380	\$21,670	\$ 82,424	\$42,735	\$122,606	\$199,590	\$184,621	\$257,748	\$282,964	\$204,890

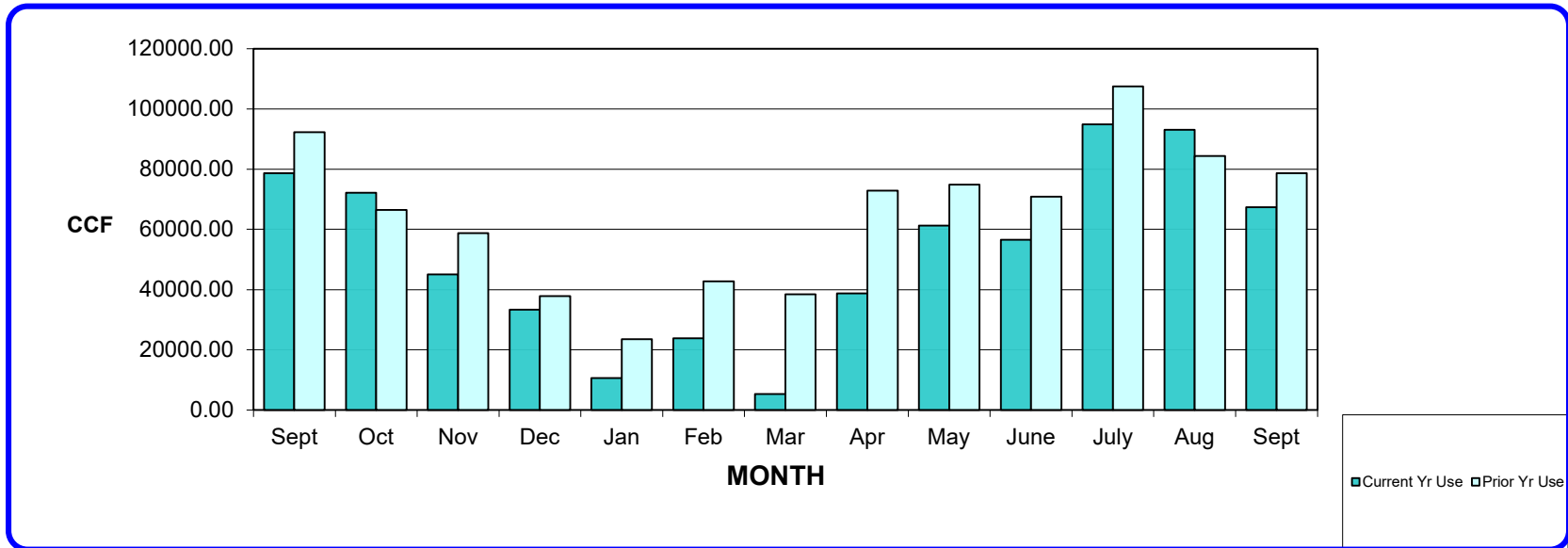

Key
2021-2022
2022-2023
2023-2024

RESIDENTIAL & COMMERCIAL SEWER USAGE AVERAGE DAILY FLOW (GALLONS per DAY per DWELLING UNIT)

	Sept	Oct	Nov	Dec	Jan	Feb	Mar	Apr	May	June	July	Aug	Sept	12-Month Average
Average Daily Flow	159	159	169	185	184	184	162	181	162	164	169	162	162	183
Prior Year Average Daily Flow	134	164	169	162	130	172	162	134	162	159	160	160	159	158

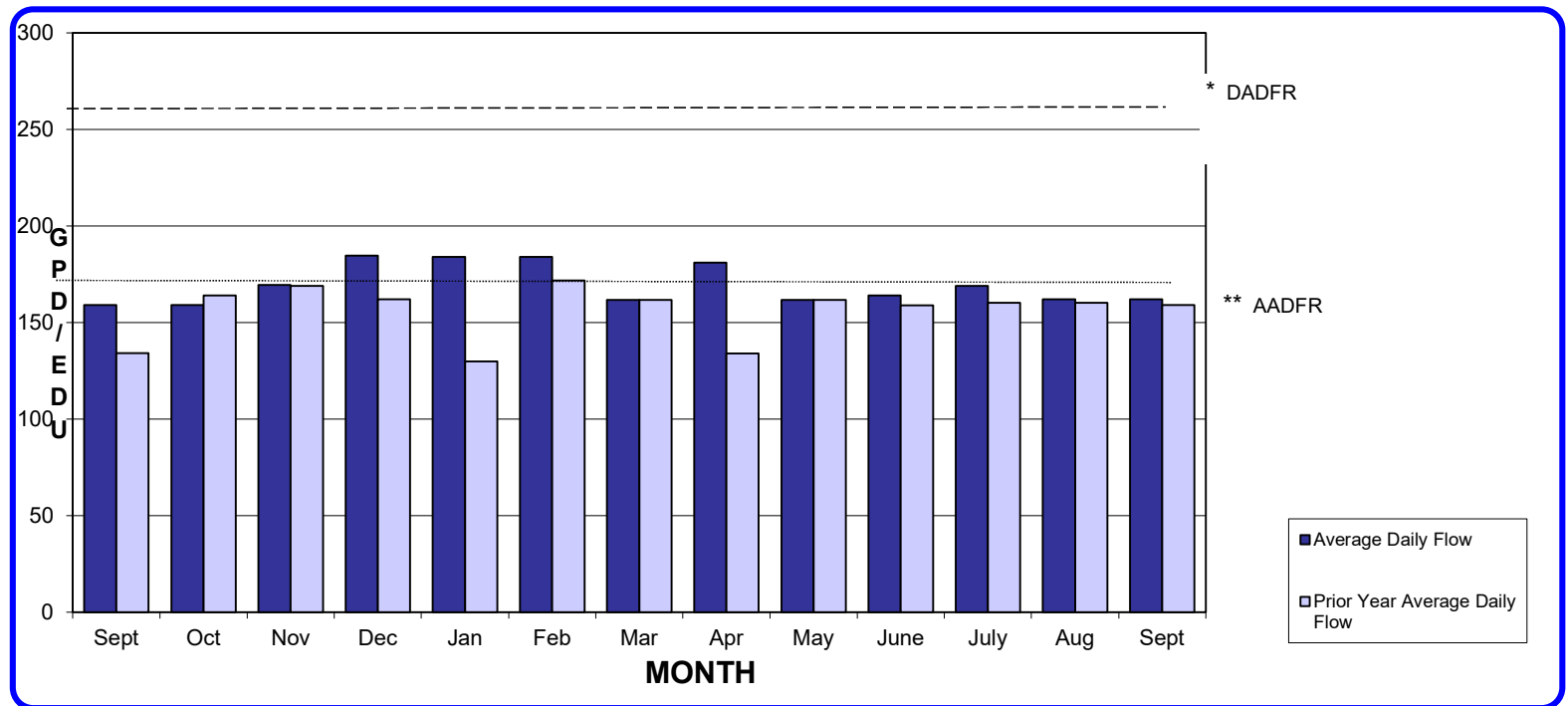

** ACTUAL AVERAGE DAILY FLOW RATE IN GPD

RECLAMATION PLANT FLOW REPORT

AVERAGE DAILY FLOW (Million Gallons)

Key	
2021-2022	
2022-2023	
2023-2024	

	Sept	Oct	Nov	Dec	Jan	Feb	Mar	Apr	May	June	July	Aug	Sept
Current Yr Avg DailyFlow	1.1460	1.1250	1.1260	1.1810	1.2950	1.2620	1.3990	1.3760	1.2730	1.2320	1.1590	1.1980	1.1860
Prior Year Avg DailyFlow	1.0940	1.0760	1.0690	1.1430	1.1400	1.1460	1.1730	1.0710	1.0760	1.0690	1.0970	1.1430	1.1460
PLANT CAPACITY	2.250	2.250	2.250	2.250	2.250	2.250	2.250	2.250	2.250	2.250	2.250	2.250	2.250

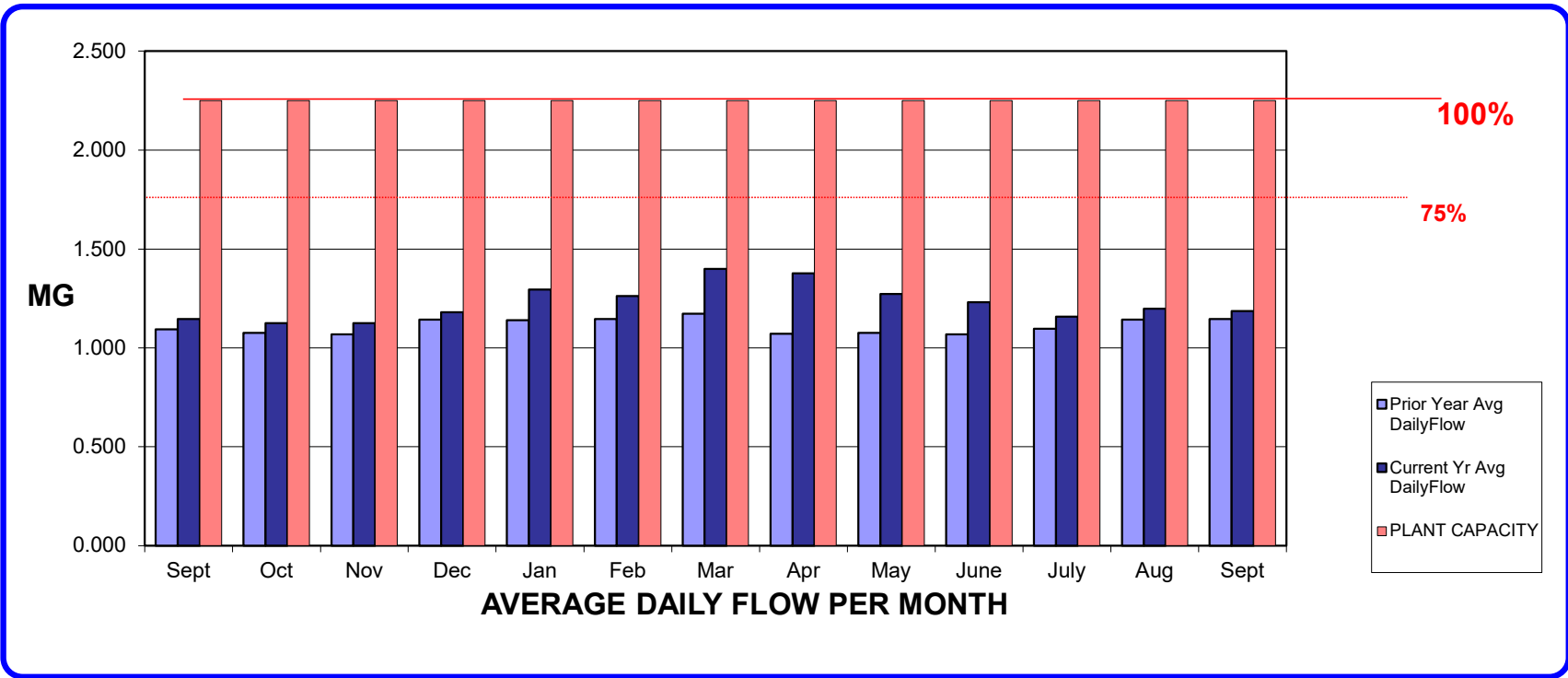

RECLAMATION PLANT DISCHARGE REPORT MONTHLY FLOW (Million Gallons)

	Sept	Oct	Nov	Dec	Jan	Feb	Mar	Apr	May	June	July	Aug	Sept	Total/yr
Current Yr Flow	34.37	34.89	33.77	36.63	40.14	35.34	43.38	41.29	39.47	36.95	36.92	37.14	35.58	451.48
Prior Year Flow	32.82	33.36	32.07	35.44	35.35	32.08	36.36	32.12	33.35	32.08	34.01	35.45	34.37	406.04

Potential Revenue

\$137,388	\$139,467	\$134,990	\$146,423	\$160,440	\$115,067	\$141,253	\$134,448	\$128,514	\$120,309	\$120,211	\$120,927	\$115,848	\$1,577,897
-----------	-----------	-----------	-----------	-----------	-----------	-----------	-----------	-----------	-----------	-----------	-----------	-----------	-------------

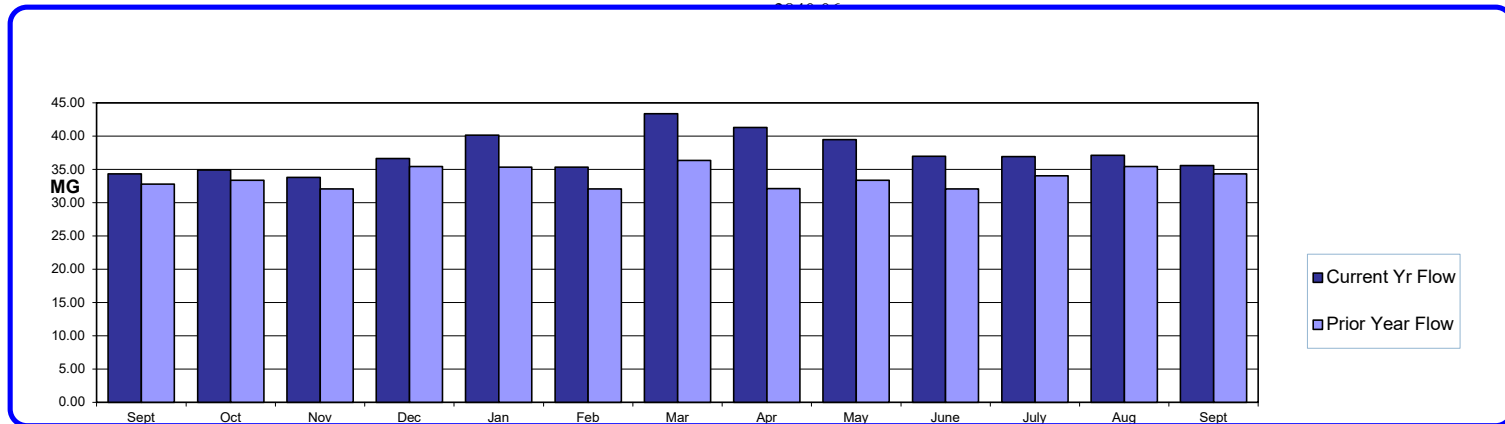

Key
2021-2022
2022-2023
2023-2024

Note - recycled water only

RECLAIMED WATER VERSUS POTABLE WATER MONTHLY FLOW (Million Gallons)

	Sept	Oct	Nov	Dec	Jan	Feb	Mar	Apr	May	June	July	Aug	Sept
No. of Sewer Dwelling Units Connected	7149	7164	7188	7204	7243	7254	7265	7293	7289	7292	7301	7330	7318
Reclaimed Water Flow	34.37	34.89	33.77	36.63	40.14	35.34	43.38	41.29	39.47	36.95	35.92	37.14	35.58
Potable Water Flow	95.60	88.19	69.13	62.62	58.58	67.07	41.13	75.16	79.86	82.43	101.86	108.40	92.41

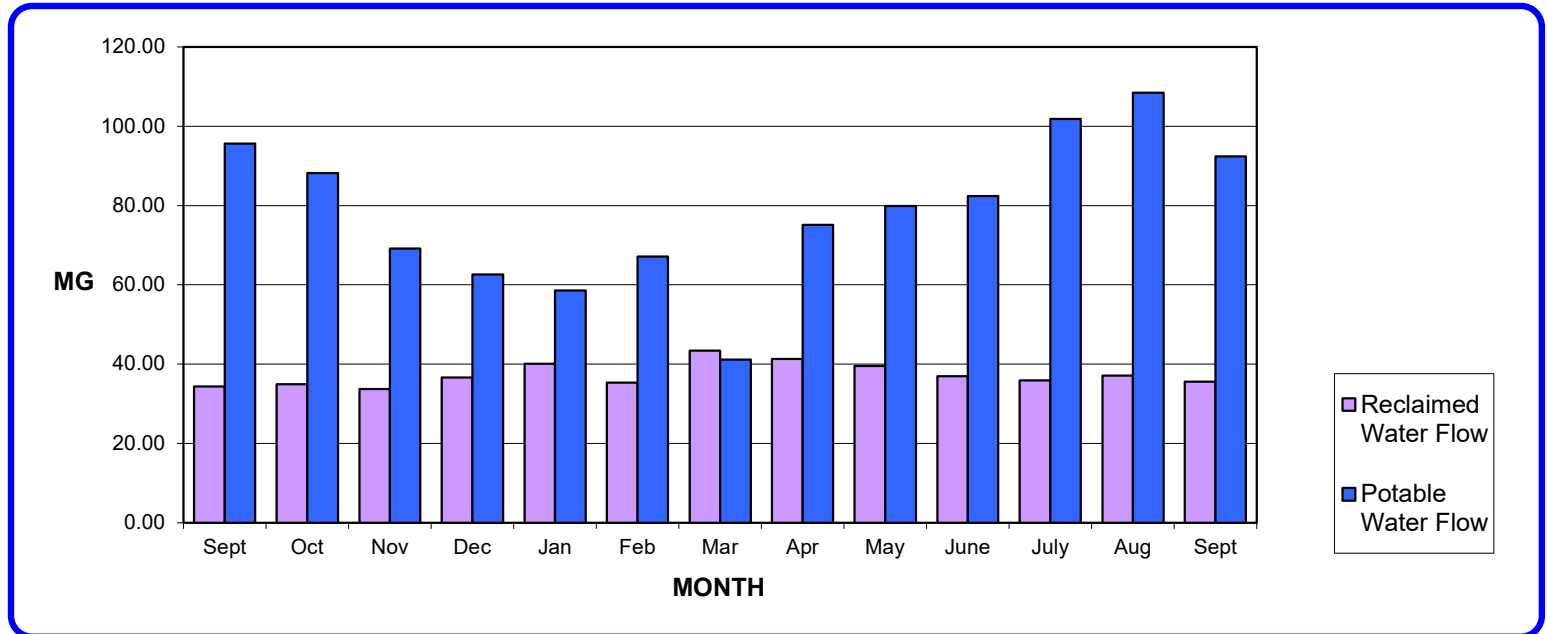

TEMESCAL VALLEY WATER DISTRICT
AVERAGE WATER UNITS PER MONTH BY ROUTE

Month	Wildrose(2)	Montecito(3)	Trilogy(4)	Painted Hills(5)	Syc Crk(6)	Retreat(7)	Terramor(8)	Harm Gr(13)	Serrano	Dist Avg	AVG / IRR (1)	TOTAL		
												RECYCLED	NONPOT- Other	NONPOT- Trilogy Golf
AVG '07-'08	18.1	32.7	15.9	32.2	21.7	37.1	0.03	-	-	25.9	83.9			
AVG '08-'09	24.6	33.8	17.0	33.3	32.6	40.8	-	-	-	25.4	53.3			
AVG '09-'10	21.9	30.0	15.8	30.2	26.3	0.0	-	-	-	23.0	51.7			
AVG '10-'11	20.6	18.68	15.5	25.8	25.1	35.2	-	-	-	22.3	36.0			
AVG '11-'12	21.0	27.9	15.9	27.3	24.7	34.0	-	-	-	22.5	82.3			
AVG '12-'13	21.9	31.3	15.6	27.5	23.6	30.5	-	-	-	22.9	q			
AVG '13-'14	22.5	33.8	16.5	28.2	24.5	30.6	-	-	-	23.0	9.8			
AVG '14-'15	20.7	28.4	15.4	26.8	21.9	28.2	-	-	-	21.2	62.8			
AVG '15-'16	17.4	21.3	10.6	22.4	16.9	24.3	-	-	-	16.5	105.4	38,401.9	4,639.1	18,977.2
AVG '16-'17	18.4	26.4	16.7	24.8	18.5	27.1	26.4	-	-	19.4	211.0	46,977.4	8,442.6	16,068.4
AVG '17-'18	18.2	22.9	14.0	25.4	18.4	27.1	16.0	-	-	18.8	378.4	48,106.6	4,904.8	16,348.5
AVG '18-'19	20.3	26.4	15.7	27.1	19.2	27.3	12.9	0.3	-	19.5	145.9	39,101.6	4,511.4	12,445.3
AVG '19-'20	20.1	24.4	15.4	25.6	18.6	27.2	12.7	6.1	-	18.9	399.3	41,168.9	3,775.2	11,460.0
AVG '20-'21	21.5	28.2	17.6	25.9	19.6	30.5	13.8	7.9	-	19.7	54.9	49,744.3	4,450.3	12,932.8
AVG '21-'22	20.3	26.1	17.9	23.9	19.3	28.0	12.5	9.7	-	19.3	56.0	42,268.8	4,212.1	15,703.4
AVG '22-'23	18.1	22.5	14.3	20.8	16.7	23.8	13.3	8.7	3.80	16.5	81.5	34,928.6	1,971.0	13,657.8
Jul-23	22.5	28.1	21.1	27.5	19.5	29.7	12.5	8.3	10.60	20.6	203.4	55,826.4	4,122.1	24,243.9
Aug-23	23.5	33.7	21.3	29.6	21.0	32.3	13.8	9.0	5.30	22.1	168.4	61,755.3	4,841.6	26,544.3
Sep-23	20.2	25.8	17.8	25.2	18.1	27.4	13.1	8.6	6.45	18.8	13.2	47,568.3	4,332.8	13,595.8
Oct-23														
Nov-23														
Dec-23														
Jan-24														
Feb-24														
Mar-24														
Apr-24														
May-24														
Jun-24														
AVG '23-'24														

NOTE: AVG UNITS PER MONTH

WHOLESALE BUDGET vs PURCHASE

Water Year July 2023 through June 2024

3800 ACFT PROJECTION)

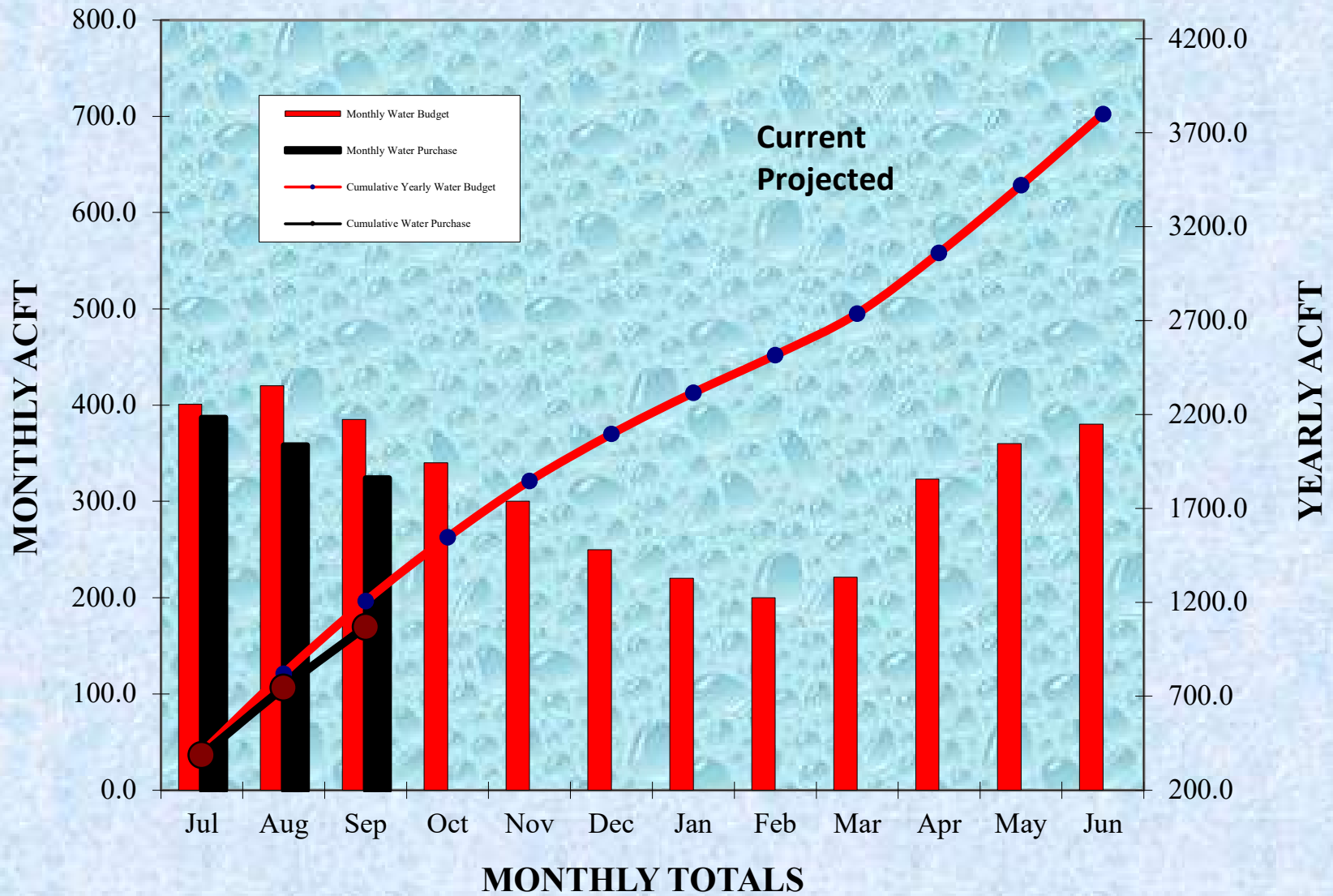



October 24, 2023

Board of Directors
Temescal Valley Water District

RE: General Manager's Report

Dear Board:

The following is a brief status report on several issues that I have been involved in since the last meeting.

- Water Supply Availability - Restrictions
 - Newsom lifted the Stage 2 Water conservation requirement – the District has moved back to Stage 1 on April 25th 2023
 - SWRCB is proposing a conservation program call “Making Conservation a California Way of Life”
- Working on non-potable water supply improvements
 - Park Canyon Drive RW line – Property owner has agreed to build the RW line along Park Canyon to our existing pipeline from the sump well.
 - Working on new well site near the Sump Booster site on the Temescal Valley Commerce Center.
 - 11-17-22 – finalizing plans for pipeline and new well site with developer design staff
 - Working on new well site at Brown Canyon Channel area on Leinen properties.
 - Good conversation with Grant on the Brown Canyon Channel Well
 - Offer received for possibly two well sites on Gail Material site.
- Working on Conservation opportunities and RW/NP conversion locations
 - Reviewing all 2” potable irrigation meters for potential conversion to RW.
 - Map complete reviewing opportunities to convert to Non-potable or RW
 - Prioritized RW conversion sites and seeking approval to provide preliminary design and cost.
 - Proposed conversion sites identified, and information sheets prepared for Engineering Committee review
 - 11-17-22 Package on board agenda for review and approval of design timing
 - 12-15-22 Plan design for draft approved projects started
 - 12-15-22 Investigation Grant opportunities
 - Design complete for Projects in our control - COR Encroachment Permits requested
 - Report by Engineering committee and District Engineer
 - Bids will be presented at the Board Meeting
 - Selection of projects and funding sources will be on the May 23rd meeting
 - Projects approved for funding by District – Contacted each HOA/Owner to solicit permissions and propose timing.
 - All areas approved by HOA/Owners for construction – Contractor in submittal stage
 - All scheduled for construction- first starts the first week of September.
- Working with Land Developers on water and sewer fees for multiple infill projects.

Temescal Valley Water District

22646 Temescal Canyon Road | Temescal Valley, CA 92883-4106 | tel: 951.277.1414 | fax: 951.277.1419
www.temescalvwd.com



- Deleo adjacent to Tom's Farms – no news
- Retreat Infill – Kiley Court – Plans signed – new Will Serve sent
- **Serrano** on Temescal Canyon Road at Campbell Ranch Road – Taylor Morris
 - **Building of the homes continues – RW meters in place**
- **Sycamore Highlands** - Kiley Family Trust Property –
 - Tract Map Stage - Public Hearing scheduled – W & S plans submitted – Requested water system study. Plans ready for signature.
 - Signed plans returned 12-13-22
 - Reviewed and made recommendation on landscape plans with RW delivery options.
 - Signed final plan set with revisions.
 - We received a request for a RW meter to start grading the site.
 - Work started on the offsite improvement to supply RW for grading.
 - **Grading and infrastructure construction continues.**
- **Rinker Property** – Map Stage – Preliminary W & S plans reviewed.
 - Amazon dropped out but the developer is continuing with a plan for commercial buildings.
 - New building layout submitted review
 - 11-17-22 Reviewed new onsite and offsite improvement plans
 - **Offsite pipeline plans in TCR were returned to the engineer with comments.**
- **TR 33688R1 - KoK Development**
 - 4th submittal in review
 - 4th Submittal returned to the engineer with comments.
 - **Developer working with California Meadows on required easements to sewer the property.**
- **TRUCK STOP and Fueling Station** –
 - Received a proposed development of a **Truck Stop** on the property across from the AM PM and adjacent to the Freeway – old shopping center site.
- **Senior Living Development on Ben Day's property.**
 - Final review of Senior Living Development infrastructure completed. Approved final layout requested actual design plans.
 - Actual Design plans on hold while the property is marketed.
 - **No change**
- **Leroy Road Commercial – LFA**
 - Working on rerouting the existing Sewer and AG water lines for the proposed Commercial Building
 - **Finalized the design with the architect.**
- **Mission Clay Products – Commercial, Apartment and Drive through**
 - **Working on new Potable water loop, Sewer and RW for site including Lawson Road**
- **Leinen Commercial Sewer Line**
 - **Reviewed, and signed the plans for a Public Sewer line in Dawson Canyon Road– includes a lateral for the Rinker site Commercial.**



- Terramor CFD – CFD 4 annexation of Phase 2 completed - Constructing the WRF expansion. Annexation of final PA in Phase 2 completed – Working on Phase 3 Water, Sewer and RW plans. Working on second Bond issuance for IA 2. Bond Issuance for IA2 complete
 - Annexation of IA3 is started.
 - Annexation complete for phase 1 of ID 3
 - 11-17-22 final reimbursement package on the 11-22 board mtg for review.
 - Developer has requested we start the annexation of the final areas in IA3.
 - Annexation of Planning Areas 14A, 14b and 11A on Agenda
 - **Annexation of Planning Areas 14A, 14b and 11A – construction started.**
- Terramor Onsite Water, Sewer and RW improvements
 - Work continues Improvement Area 2 – Richmond America, Pardee and Pulte. Grading of Phase 3 pads will be complete in August. Developer currently building the upper zone booster.
 - Upper booster complete and in operation – final testing and connection to SCADA in the works
 - Work continues on the water, sewer and RW in ID 3
 - 12-15-22 Signed plans returned for all final phases in ID3
 - **Work continues on water and sewer improvement for Phase 3**
- AMI/AMR Meter Reading system upgrade
 - Research continues on different data collection systems, software and meters.
 - Expecting final coverage proposal prior to September Board meeting.
 - Working on the RFP to be given to each of the system providers for review by the engineering Committee
 - Working with Western on Grant opportunities prior to bidding/RFP
 - Soliciting a proposal from a company called METERSYS as a resource to investigate, rank and prioritize the changing AMI products.
 - Proposal received – reviewing.
 - **Proposal Signed and work started.**

Sent via ELECTRONIC MAIL to commentletters@waterboards.ca.gov and orpp-waterconservation@waterboards.ca.gov.

October 17, 2023

The Honorable E. Joaquin Esquivel
Chair, State Water Resources Control Board
P.O. Box 100
Sacramento, CA 95812-2000

James Nachbaur
Director, Office of Research, Planning and Performance
State Water Resources Control Board
1001 I Street, 24th Floor
Sacramento, CA 95814

RE: Comment Letter — Making Conservation a California Way of Life Proposed Regulation

Dear Chair Esquivel,

On behalf of the undersigned agencies across San Bernardino and Riverside Counties, we are submitting this regional letter to express significant concerns with the proposed regulations for *Making Conservation a California Way of Life*. Our requested revisions focus on ensuring the 2035 standards are realistic and attainable and avoid setting requirements and establishing responsibilities for water suppliers that go beyond their authority to enforce.

Our top regional concerns and requests revolve around the following themes:

1. The outdoor standards, as written, are not reasonable nor attainable for inland agencies, and remove all flexibility that would account for our naturally arid region. The stringent and inequitable requirements would require that inland agencies infringe upon our customers' freedom of choice, forcing the removal of front and backyard living and play spaces, the elimination of pools, and the degradation of lifestyles for the most vulnerable populations across our region.
2. Our investments in local water supply projects, including recycled water, must be taken seriously, and be considered permanent investments.
3. While conservation is an important tool, it must be understood that conservation alone will not save us from future droughts. Investments must be made in developing new water supplies to balance out the dual approach to water supply reliability.

Across our combined service areas, we serve **XX** million people and are part of the fastest growing region in California. With that said, we also find ourselves in a naturally arid climate that regularly experiences major heat events. We also have a significant number of disadvantaged and severely disadvantaged communities throughout our region, which makes the costs and lifestyle impacts of implementing any program even more important to each of us.

Over the last 30 years, Southern California has gone above and beyond to make conservation a way of life for our region. Overall water use has decreased over this period even though the population has increased by several million. While there may be more that we as Californians can do to be more efficient with our water use, the State should recognize our past efforts and acknowledge the significant and burdensome expenses that will be placed on residents and business owners to achieve the proposed deeper level of reduction and substantial lifestyle changes being considered. Furthermore, the rate- and tax-paying residents of California deserve a level of local flexibility to implement water efficiency programs that work in their homes and climate regions.

Each one of the agencies on this letter plans on submitting their own individual comment letters by the October 17 deadline to ensure each unique perspective is heard. The purpose of this letter is to reiterate the collective requests and concerns from across our region that we all share and need to be addressed. While supporting the Association of California Water Agencies' specific and technical revisions to the text, our agencies are requesting the following changes:

Outdoor Standard

Requested Change: Extend a 0.8 landscape efficiency factor (LEF) through June 30, 2035, then adjust to a 0.63 LEF through June 30, 2040, with an industry-standard irrigation efficiency (IE) factor in the formula. Beginning July 1, 2035, the State Water Board, in partnership with no less than 30% of inland water suppliers, shall assess if the standard for efficient residential outdoor use at a 0.63 LEF is being met by more than 60% of residential customers. All future regulatory proposals that set a standard for efficient residential outdoor use lower than 0.63 LEF must demonstrate a real-world application and retention factor of 0.63 LEF in the inland regions and across disadvantaged communities for no less than five (5) years.

Reasoning: A 0.55 LEF is unrealistic and unattainable, especially in inland regions. The lack of an irrigation efficiency factor in the water use standard deprives all plant material of vital water necessary to thrive in any climate at any LEF. Furthermore, many water suppliers are not land use agencies and cannot require customers to retrofit their existing front and backyard landscapes, demolish and remove pools, and eliminate all forms of turf, all of which would be required to meet an overly restrictive LEF. The 2015 MWEL design standard is not currently being achieved in real-world landscapes, yet the proposed regulations would reduce water deliveries to the design standard, which is enforceable via fines. Although the proposed standards are aimed at the water supplier level, the sources of funding for levied fines will rest on customers. The entities that will have to pay for these regulations are the California home and business owners.

Irrigable-not-Irrigated (INI) Landscape Area

Requested Change: The Outdoor Residential Standard should be applied to 100% of an irrigated landscape area and 20% of an INI landscape area through 2035 and beyond.

Reasoning: Post-2027, agencies will be required to prove that INI areas are now irrigated by annually remeasuring their landscape areas so that their budget more closely reflects efficient use. This would be infeasible to obtain new estimates every year, and the timeframe would likely mean the update would not be included on time. Requiring this is also not equitable to small and disadvantaged communities, and this inequity could unintentionally impact their compliance with the framework. If the proposed revision is not selected, the State should pay for and

manage the irrigated landscape updates biennially with data within two years of the reporting date.

Effective Precipitation

Requested Change: Calculate Effective Precipitation monthly for each agency. Effective precipitation should be removed from calculating the outdoor standard. "NET ETO" should be replaced with ETO throughout the document.

Reasoning: The current calculation for effective precipitation is disproportionately impacting Inland agencies. Although these objectives consider local weather, the annual effective precipitation rate calculated annually decreases an Inland agency's overall objective due to the timing and flashiness of our region's rainfall. For example, heavy precipitation in February does not mean a plant will use less water in July.

Commercial, Industrial, and Institutional (CII)

Requested Change: CII classification, Best Management Practices (BMPs), and mixed-use meter (MUM) reporting by 2035 and phase the implementation of the BMPs by 1-2 years from the timeline of the classification (DWR recommendations).

Requested Change: Design and implement a conservation program for customers at or above the 80th percentile for water use (total water use, not specific to EnergyStar Portfolio Manager's Categories). If CII customers make up less than 5% of an agency's total potable water use, then the agency should be exempt from this requirement.

Requested Change: The focus should be on making programs available and not dependent on customer program adoption.

Requested Change: Change language to give the ability to implement BMPs through existing and regional programs. One program can cover multiple BMPs, and one BMP can be used for numerous/ all classifications.

Reasoning: There is a tremendous amount of investment each agency needs to make to "attempt" to reach these targets. However, due to the aggressive nature of the framework, agencies will always fall short because we are indebted to what the public participates in. The proposed framework does not allow flexibility for programs to align with locally appropriate, existing programs that are cost-effective and can be focused on achieving the most savings. The performance measures demonstrate misalignment with existing, successful programs, are infeasible, especially for under-resourced agencies, and are not fiscally responsible. Resources and operational intensity are beyond current practices.

Temporary Provisions

Requested Change: Pools, spas, and similar water features should not be considered a temporary provision. The LEF factor for pools should be set at 1.0.

Reasoning: Customers have made significant home investments that are not "temporary."

VariANCES

Requested Change: Make the accounting process for potential variances not onerous for water agencies to implement.

Reasoning: As written, water agencies must have to account for and report to the State Water Board the following:

- i. The number of evaporative coolers a customer has.
- ii. Seasonal population fluctuations.
- iii. The number of horses and other livestock on a property.
- iv. The landscaped areas are irrigated with recycled water that has high TDS.
- v. Dust control measures.
- vi. Ponds and lakes to sustain wildlife.
- vii. Water for emergency events (excluding droughts).
- viii. Residential agriculture.

Collecting this information for annual reporting to the State Water Board is unrealistic and overly demanding on the water supplier trying to meet their Urban Water Use Objective.

In closing, we want to make the critical point that **urban conservation alone will not save us from future droughts**. Programs and efforts to ensure Californians are efficient with their water use are practical tools. However, the estimated cost to implement the proposed actions Statewide ranges from \$8 to \$15 billion to reduce Statewide water use by approximately 1.5%. This is a very large price tag with a substantial impact to lifestyles for California's residents and business owners. There is no way we'll make it through the next long drought by paying for efforts to meet the proposed standards alone. State and local water agencies **must** work together to create the means to increase the State's overall water supply. The State must invest significantly in projects that will increase the ability to capture, store, and move water during wet years. The State must prioritize necessary infrastructure investments and work with the water community so that instead of managing for scarcity, the State is working toward water supply targets to ensure we have enough water for communities, businesses, agriculture, and the environment.

The undersigned agencies appreciate the consideration of our comments and look forward to working with the State Board to ensure realistic and achievable goals for the success of the Conservation as a California Way of Life Framework.

If you have questions regarding these comments, please contact Craig Miller, General Manager of Western Municipal Water District, at cmiller@wmwd.com or 951.571.7282.

Very Respectfully,



Craig Miller, P.E.
General Manager
**Western Municipal
Water District**

DRAFT

MEMORANDUM

DATE: October 24, 2023
TO: Board of Directors
Temescal Valley Water District
FROM: General Manager
SUBJECT: Portable Potable Water Reservoir Management System.

BACKGROUND

Please see the attached CIP project sheet from FY 21/22. Staff was working on providing for the installation of an on-site permanent residual control systems for each of the four large reservoirs in our system. The attached CIP was for the Terramor tank and was contemplated to be placed inside the new upper zone water booster station. Last year we completed the installation of tank mixers in three of the tanks downstream from the Wildrose tank. Each of the tanks needs a residual boost at different times, and since each system can cost upwards of \$200k for a permanent installation, we researched and found a portable system that is in a custom trailer. This trailer can be moved from site to site as needed and stored in our yard for safety.

This trailer allows the District to forgo the purchase and installation of permanent systems for all tanks.

FY 21/22 budget	\$103,000.00
Portable unit.	\$148,900.00
Increase in line item budget:	\$45,900.00

FISCAL IMPACT

\$148,900.00

RECOMMENDATION

At the discretion of the Board:

1. *Move additional funds needed to CIP W-3-2021.*
2. *Authorize the General Manager to purchase the system.*

Respectfully submitted,

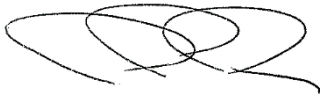

Jeff Pape
General Manager



Project Name: Reservoir Management Systems

Project Department: Water

CIP Project No.: W-3-2021

Total Project Cost: \$ 102,000

Project Description:

The State Water Resource Control Board – Drinking Water Division requires the District to maintain a minimum residual in the domestic water system, including the tanks. Tank water is typically difficult to keep at minimum residual unless you cycle the tank down to a level that is problematic if our source of supply is interrupted. We also are required to minimize the Disinfection Byproducts created by high residual. Reservoir Management Systems can be as simple as a mixing system or more complicated by mixing and adding disinfection to the tank water. We added mixing systems to three tanks, Trilogy, Sycamore Creek and Terramor in FY 20-21. With this project we will be purchasing and installing the equipment for Chloramine injection in the Terramor Tank. The new upper booster is being plumbed during the construction for the new equipment.

Budget Summary by Phase :

Phase	FY 21-22	FY 22-23				Total
Purchase	\$ 77,000					\$ 77,000
Installation	\$ 25,000					\$ 25,000
						\$ -
TOTALS	\$ 102,000					\$ 102,000

Project Schedule Summary by Phase:

Purchase					
Installation					

Funding Source

Sewer Fund						\$ -
Potable Water Fund	\$ 102,000					\$ 102,000
Recycled Water Fund						\$ -

October 17, 2023

Temescal Valley Water District

Attn: Paul Bishop

Subject: One (1) Trailer-Equipped Chemical Feed System and Tank Mixer For Managing Drinking Water Reservoir Disinfection

D & H Water Systems, Inc. is pleased to offer the following proposal for your consideration.

QTY [1] Big Wave Water Technologies Chloramine Boosting System Trailer

- Qty [1] Big Wave Water CBS Control Panel
 - o 10" Touch Screen
 - o CBS Control Logic
 - o 24" W x 30.5" H x 14" D NEMA 4X FRP Enclosure

- Qty [1] ProMinent DACb Total Chlorine and ORP Analyzer
 - o Total Chlorine and ORP Probe
 - o Qty [4] 420mA Analog outputs
 - o Reagent-less Chlorine Analyzer

- Qty [1] Single D&H Peristaltic Pump Skid for 12.5% Sodium Hypochlorite
 - o Qty [1] ProMinent DFXa Peristaltic Metering Pump
 - Pump can operate in pressures up to 125 PSI
 - Pump feed-rate: 0 – 8 GPH
 - NSF 61 Certification
 - 3,000:1 Turndown
 - o Skid made on high density marine grade chemical resistant polyethylene
 - o All joints shall be socket welded and have a warranty to be leak free for 5 years
 - Wherever a serviceable item is located a true union ball valve will be used for ease of maintenance.
 - o Skid to include:
 - Qty [1] Griffco Cal Column 100 ML
 - Qty [1] Blue White Flow Indicator
 - Qty [1] Griffco Pressure Relief Valve
 - Qty [1] Ashcroft Pressure Gauge and gauge guard filled with halocarbon

- Qty [1] Ashcroft Pressure Switch
 - Qty [1] Plast-O-Matic Diaphragm Type Check Valves
 - All components shall be pre-plumbed and pre-wired on skid
- Qty [1] Single D&H Peristaltic Pump Skid for Ammonia
 - Qty [1] ProMinent DFXa Peristaltic Metering Pump
 - Pump can operate in pressures up to 125 PSI
 - Pump feed-rate: 0 – 8 GPH
 - NSF 61 Certification
 - 3,000:1 Turndown
 - Skid is built out of high density marine grade chemical resistant polyethylene
 - All joints shall be socket welded and have a warranty to be leak free for 5 years
 - All serviceable items shall have a union or true union ball valve will be used for ease of maintenance.
 - Skid to include:
 - Qty [1] Grifco Cal Column 100 ML
 - Qty [1] Blue White Flow Indicator
 - Qty [1] Grifco Pressure Relief Valve
 - Qty [1] Ashcroft Pressure Gauge filled with halocarbon and protected by a gauge guard
 - Qty [1] Ashcroft Pressure Switch
 - Qty [1] Plast-O-Matic Diaphragm Type Check Valves
 - All components shall be pre-plumbed and pre-wired on skid
- Qty [1] Sample recovery system
 - March magnetic drive centrifugal pump
 - Sample recovery venturi panel to enable sampled water to be returned to reservoir
- Qty [1] 7'X14' Load Runner or Equal Trailer
 - Coin Pattern Flooring
 - Rhino Lined Interior Painted Coat
 - Dual Axel
 - Electric Brakes
 - Customer Specified Placarding
 - **250 Gallon** 12.5% Sodium Hypochlorite dual containment storage tank.
 - **65 Gallon** 40% LAS dual containment storage tank.
 - (2) Viatran Level Sensors for chemical storage tanks.
 - Exhaust fan
- All Components Shall be Mounted, Wired Together, and Tested Before Delivery is Made
- RV Air Conditioning Unit to be installed on Trailer for Temperature Control

— Qty (1) TWM 15 Tidal Wave Water Mixer

- HDPE mixer frame with 316 SS fasteners.
- 1.5 HP, 230VAC 3ph, Water Filled/Lubricated continuous duty motor
- Nylon propeller with life time warranty.
- Input power 120V 14 Amps, 1,800 Watts Power Draw
- 50' of 4 wire flat jacketed Cable.
- Flat jacket cable hub for tank penetration.
- Mixer sized for 500,000 to 10MG reservoirs.
- UL Certified to NSF/ANSI 61 and NSF/ANSI 372
- Overall weight of Mixer 35 lbs.

— Qty (1) TWM 15 Tidal Wave Water Mixer Control Panel

- Type 4 Nema painted steel lockable enclosure.
- Cooling fan with filter.
- Red and Green indicator lights for mixer status and power.
- WEG VFD rated for 2HP.
- On/Off switch
- Manual speed adjustment
- High and low current protection.
- Low water level auto shut off.
- Line load reactor
- 20 amp internal circuit breaker
- SCADA outputs:
 - Dry contact for mixer operating
 - 4 20mA for mixer condition (Current draw).
- Operating temperature range 4 °F to 129 °F
- Overall weight of control panel 40 lbs.

Qty [2] Day of Start up and Training

Qty [1] Freight

Total Charges

\$148,900.00

Taxes to be charged upon invoicing

Conditions of Sale:

- D&H Water Systems is serving as an equipment supplier.
- Payment terms: (*upon approved credit*) Net 30 days after shipment of equipment with no retainage.
- This quote is firm for 30 days.
- Quotation does not include any taxes.
- All Visa and Master card transactions will incur a 4% pass through service charge.
- Submittals provided 1-2 weeks after purchase order is fully executed by both parties.
- Delivery will be made in approximately 16-22 weeks after submittal approval.
- D&H reserves the right to adjust lead times if purchase order is submitted more than 30 days after proposal date.
- This quotation is limited to the products and services as listed, and excludes any item or service not listed.
- D&H Water Systems' standard insurance package covers commercial general, automotive, worker's compensation, and umbrella liability. We do not provide professional liability. Any costs associated with additional insurance requirements will be passed on to buyer.
- D&H will not be held liable for any liquidated damages incurred during project.
- This quotation EXCLUDES any permits, licenses, bonds, inspections or fees.
- This quotation EXCLUDES seismic calculation of any kind unless specifically noted in scope of supply.

All resulting purchase orders should be sent to:

D and H Water Systems, Inc.
603 Seagaze Drive #241
Oceanside, CA 92054

Please do not hesitate to contact me if you have any questions or require further information.

Best,

Tommy Hartwig
Tom@dandhwatersystems.com
760.468.8006



Tidal Wave Water Mixer

We are proud to offer our new active water mixer that meets or exceeds industry standards, out-performs the competition, and is economically priced.

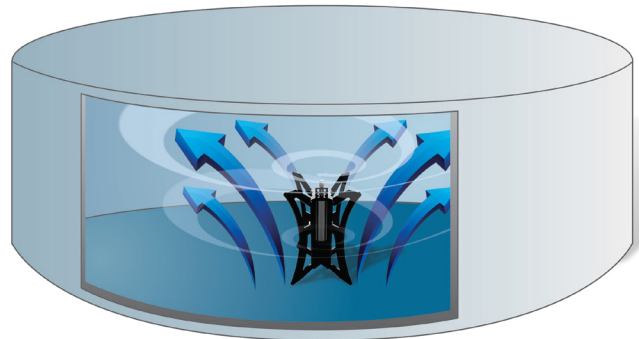

- *Improves water quality in storage tanks*
- *Performs in tanks up to 10 million gallons or more*
- *Eliminates stratification*
- *Reduces nitrification in chloraminated systems*
- *Exceeds mixing requirements for addition of chemistry*
- *Reduces bacteria growth and lowers DBP's (disinfection by-products)*
- *Improves water taste and odor*
- *Improves water tank longevity*
- *Helps prevent ice damage in cold climates*
- *Lowered through hatch, no diver required*
- *May improve energy efficiency*
- *Solar options available*
- ***3 year warranty***

We've brought to market an active water mixer that greatly improves water quality and storage tank longevity at a very competitive price.

For more information or to schedule a presentation, please call **667.244.9283 (667.BigWave)** or visit **BigWaveWater.com**





Tidal Wave Water Mixer Specifications

Control Center Power	120 VAC / 1Ph / 60Hz, 20 amp circuit
Motor Type	NSF 61, 1.5HP, 120/230 VAC, water-filled, water-lubricated
RPM	3100
Power Draw	14 amps, 1800 watts
Footprint Diameter	23" (58.42 cm)
Height	30.75" (78.10 cm)
Weight: Mixer Assembly	35 lbs. (15.87 kg)
Control Center Dimensions	40 lbs. (18.14 kg) (20" x 16" x 6" / 50.8 cm x 40.64 cm x 15.24 cm)
Material: Control Center	Powder-coated steel, Type 3R enclosure
Material: Stand	HDPE
Material: Motor Seals	Chlorine/chloramine-resistant NBR rubber
Wiring	NSF 61 & UL-listed submersible pump cable 14 AWG (2.1 mm ²) XLPE (.78" x .28" / 20 mm x 7 mm)

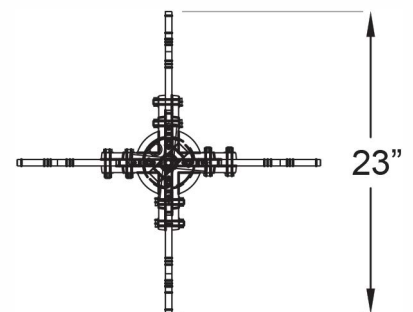
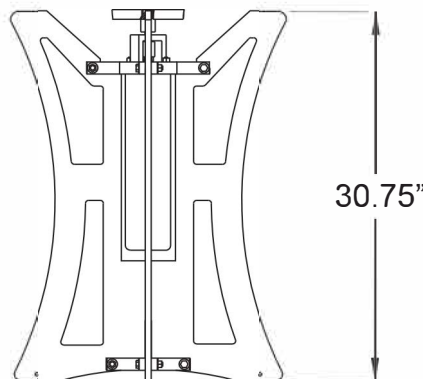



CHLORAMINE BOOSTING SYSTEM

The **Big Wave Water Technologies CHLORAMINE BOOSTING SYSTEM (CBS)** is a flexible, precise, and dependable system for maintaining consistent free or total chlorine residual in water reservoirs. The **CBS** maintains uniform water quality throughout the entire reservoir by preventing stratification while accurately dosing sodium hypochlorite and/or ammonia with minimal operator involvement. The highly accurate chlorine residual analyzer and its ability to measure either Free or Total chlorine residuals, in conjunction with the operator interface, allows the **CBS** to control to the operator selected set point. From potable water reservoirs to standpipes, the **CBS** helps operators gain control of water quality in both the reservoir and distribution system.

Applications

- Reservoirs
- Standpipes
- Distribution Systems

Key Benefits

- Continuous measurement of water quality
- Decrease in maintenance hours
- Control reservoir remotely
- Reduce need for tank cleaning
- Reduce chemical inventory
- Low power consumption
- Solar options available
- Modular design
- Proven amperometric reagentless chlorine measurement
- Chemical dosing control to an operator selected point
- Maintain uniform water quality throughout the reservoir
- Various disinfection methods can be utilized
- Portable systems available
- Demo units available
- Results guaranteed

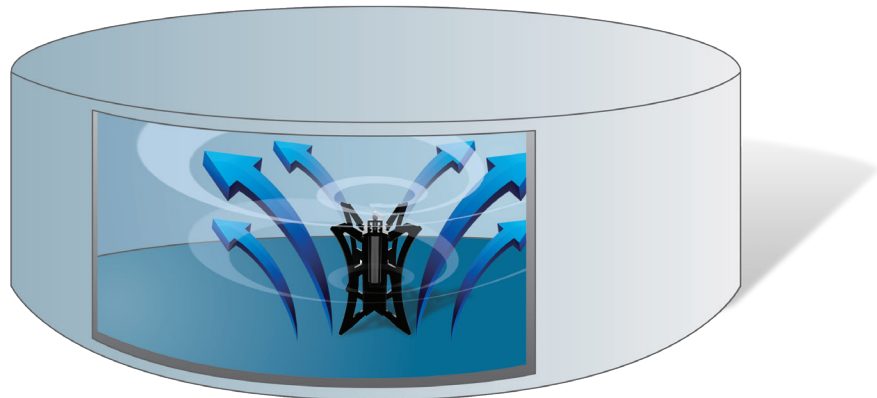

1-10 MG Reservoir

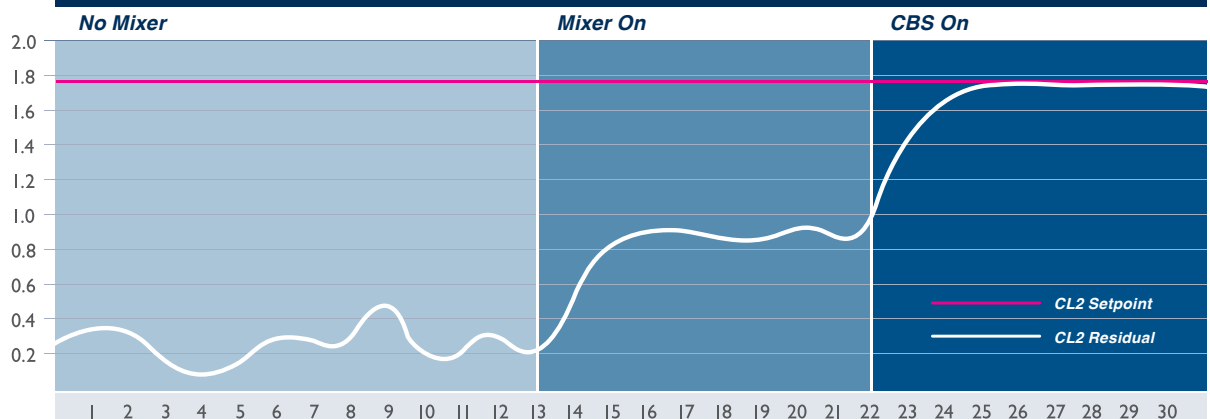

Uncirculated reservoirs tend to have low residuals throughout the reservoir, especially at the upper levels. When reservoirs are circulated, the residual tends to be higher and uniform throughout the entire reservoir. The Chloramine Boosting System allows the operator to set an ideal residual level throughout the entire reservoir.



Big Wave Water Technologies believes in a very simple and effective equation for success.

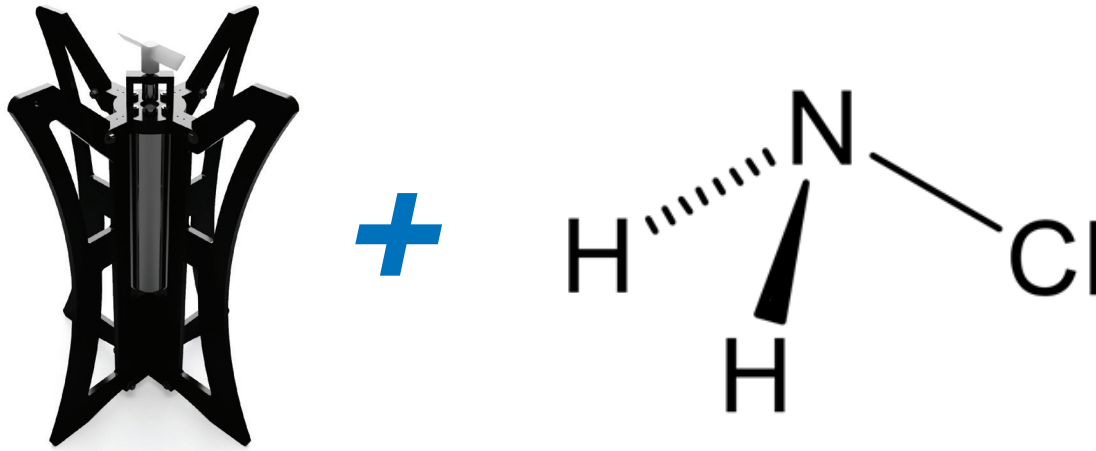

POWERFUL MIXING + CHEMICAL ADDITION = CHLORAMINE BOOSTING SYSTEM

1. Our active mixer meets or exceeds industry standards, out-performs the competition, and is economically priced.
2. Our Chloramine Boosting System works with customer preferred or existing chlorine analyzer.
3. Our proprietary control panel is reliable, operator friendly, and easy to use.
4. The control panel regulates the chemical addition.



1. 2.
4. 3.

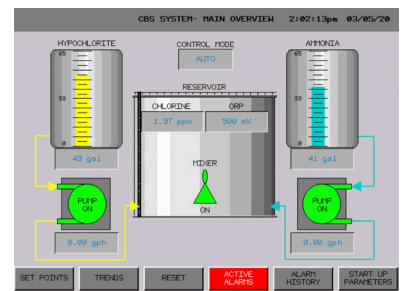

For more information or to schedule a presentation, please call **667.244.9283 (667.BigWave)** or visit **BigWaveWater.com**

Control Panel

Product Specifications

CBS CONTROL PANEL



PRODUCT INFORMATION

The CBS Control Panel gives operators the ability to program residual level setpoints, chlorine to ammonia ratios, chemical feed rates, and alarms

- 24/7 water quality analysis
- Remote monitoring
- Touch screen enabled

CONTROL PANEL SPECIFICATIONS

Power Requirement	120VAC, 10 amp circuit breaker
Remote Connectivity	Yes
SCADA Connectivity	Yes
Safety Features	Emergency stop button on panel
Data Trending	Yes
Internal Memory Backup	Yes
Screen	10" LCD Touchscreen
Enclosure	NEMA 4X FRP
Dimensions	24" W x 30.5" H x 14" D

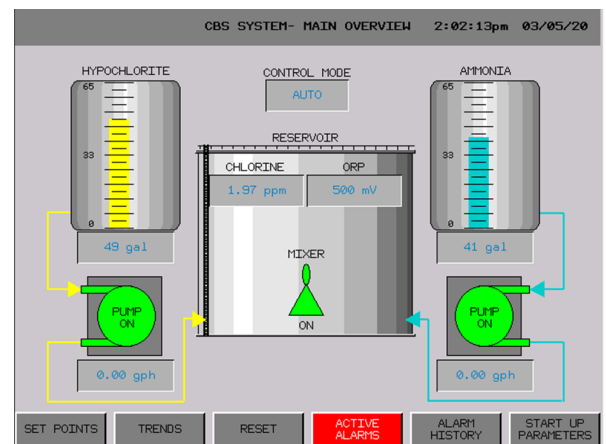
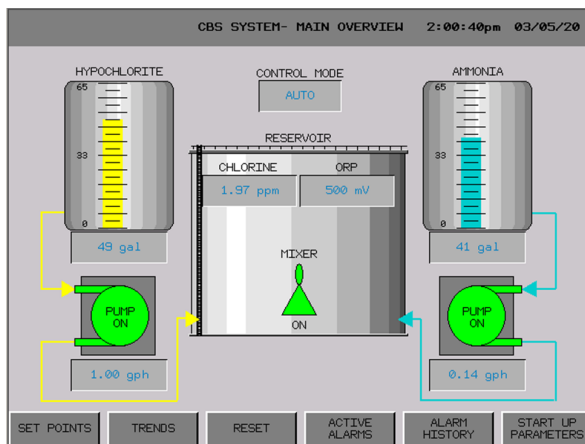

For more information call 667-BIG-WAVE

www.BIGWAVEWATER.com

DULCOMETER® DACb Controller

Intelligent measuring and control



ProMinent®

ProMinent® introduces its latest multi-parameter controller, the **DACb**. Built on the existing DACb platform, the DACb now offers one, two or three channels for the continuous measurement and control of process variables in water and wastewater applications.

The large screen HMI allows for easy viewing of process events and changes color when faults occur. Datalogging and SD card storage allows the operator to keep valuable information for over a year!

Packaged in a NEMA 4X enclosure, the DAC offers more flexibility for industrial and municipal projects by offering measurement of 14 process variables, pH and temperature compensation, feed forward and up to three analog outputs. Create a complete packaged system by adding sensors, flow cell, plumbing and backpanel.

Features & Benefits

- One, two or three channels
- 2-way PID control
- Data and event logging with SD Card (optional)
- Three analog outputs
- Seven digital inputs
- Four frequency outputs
- Two powered relays
- Measured value trend display
- pH compensation for Free Chlorine
- Temperature compensation for pH, conductivity, and fluoride
- NEMA 4X enclosure
- LAN/ Ethernet Connectivity available Q2 2018
- Profibus®-DP, Modbus RTU
- Optional 24V DC power

DULCOMETER® DACb Controller

Specifications

Measuring range	
mV connection type	pH: 0.00 - 14.00
	ORP voltage: -1,500 - +1,500 mV
Connection type mA (amperometric measured variables, measuring ranges corresponding to sensors)	Chlorine, Chlorine dioxide, Chlorite, Bromine, Ozone, Hydrogen peroxide (PER sensor), Hydrogen peroxide (PEROX sensor with PEROX transducer V2 Order No. 1047979), Peracetic acid
Connection type mA (potentiometer measured variables, measuring ranges corresponding to the transmitter)	pH, ORP voltage, Fluoride
Conductivity (measuring ranges corresponding to the transmitters)	via Transmitter 0/4 - 20 mA
Temperature	via Pt 100/Pt 1000, measuring range 0 - 302 °F
Resolution	
	pH: 0.01
	ORP voltage: 1 mV
	Temperature: 32 °F
	Amperometric analysis (chlorine etc.): 0.001/0.01 ppm, 0.01 vol. %, 0.1 vol. %
Accuracy	0.3 % based on the full-scale reading
Measurement input	pH/ORP (input resistance > 0.5 x 10 ¹² Ω)
Temperature compensation	Pt 100/Pt 1000 for pH, conductivity, and fluoride sensors
Correction range	0 - 212 °F
pH compensation range for chlorine	Sensor CLE 3 and CLE 3.1; 6.5 - 8.5, sensor CBR 6-5 - 9.5
Disturbance signals/feed forward	Flow via 0/4-20 mA or contact water meter 1 - 500 Hz, the interference variable acts on both channels
Control characteristic	P/PID control
Control	2 x bidirectional control
Analog outputs	3 x 0/4-20 mA electrically isolated, max. load 450 Ω, range and assignment (measured, correction, control variable) can be set
Control outputs	4 x 2 pulse frequency outputs for metering pump control, 2 relays (limit value, 3-point step or pulse length control)
Alarm relay	250 V ~3 A, 700 VA contact type changeover contact
Digital control inputs	(7) as a remote control input for the functions pause control / sample water fault, parameter set switch-over, level monitoring of chemical tanks
Electrical connection	90-253 V, 50/60 Hz, 25 VA or 24 V DC
Field bus connection	PROFIBUS - DP, Modbus RTU
Ambient temperature	0 - 122° F (for indoor installation or with a protective enclosure)
Enclosure rating	
	Wall mounted: IP 67 (NEMA 4X)
	Installation in the control cabinet: IP 54 for control cabinet door
Tests and approvals	CE, MET (corresponding to UL according to IEC 61010)
Housing material	PC with flame proofing equipment
Dimensions	9.84 x 8.66 x 4.80 in. (WxHxD)
Weight	3 lbs.



ProMinent Fluid Controls, Inc.
136 Industry Drive • Pittsburgh, PA 15275 USA
(412) 787-2484 • Fax: (412) 787-0704
email: sales-US@prominent.com www.prominent.us

© 2018 ProMinent Fluid Controls, Inc.
All Rights Reserved.

PN: 7750242
DACb.indd rev0 01/10/2018

ProMinent® Reagent-Free Analyzers

Complete Disinfection Packages

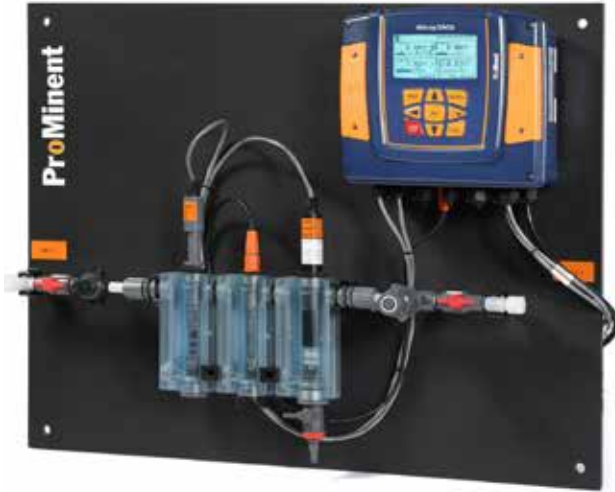

Free Chlorine Package



Fluoride/Total Chlorine Package

ProMinent® analyzers and controllers provide precise monitoring and control of process variables for potable water and wastewater applications. Our **Reagent-Free** amperometric sensor technology utilizes an on-line measurement of disinfection chemicals while using no colorimetric reagents or photometric equipment.

Our analyzer packages cover a wide range of measurements for Free Chlorine, Total Chlorine, Fluoride, Peracetic Acid and Hydrogen Peroxide. One part number covers the entire package which includes the DAC analyzer, sensor, flow cell, back panel, plumbing and wiring components.

Features & Benefits

- Reagent free sensor technology
- Monitors and Controls
- Controls up to 3 variables
- Pre-plumbed, wired and mounted
- EPA method 334.0 compliant for Cl
- 3 mA outputs
- Plug & Play design
- No service contract required
- Real time process control
- Data logger and SD card
- Modbus RTU

ProMinent® Reagent-Free Analyzers

Analyzer Packages

Part Number	Package Type	Part Number	Package Type
Chlorine			
1055407	2 PPM Total Chlorine	1083297	5 PPM Total/Total Chlorine
1055408	2 PPM Free Chlorine/pH	1093232	5 PPM Free/Total Chlorine/pH
1080700	2 PPM Total Chlorine/pH	1049062	10 PPM Total Chlorine
1083296	2 PPM Total/Total Chlorine	1049063	10 PPM Free Chlorine/pH
1093231	2 PPM Free/Total Chlorine/pH	1080702	10 PPM Total Chlorine/pH
1079048	5 PPM Total Chlorine	1083298	10 PPM Total/Total Chlorine
1079050	5 PPM Free Chlorine/pH	1093233	10 PPM Free/Total Chlorine/pH
1080701	5 PPM Total Chlorine/pH	1081716	20 PPM Total Chlorine/pH
Fluoride			
1058259	10 PPM Fluoride/ 2 PPM Total Chlorine		
1093227	10 PPM Fluoride		
Hydrogen Peroxide (H₂O₂)			
1082570	2,000 PPM Hydrogen Peroxide		
Peracetic Acid (PAA)			
1093229	200 PPM Peracetic Acid		
1093230	2,000 PPM Peracetic Acid		

Drawing - Chlorine/Fluoride package detail shown

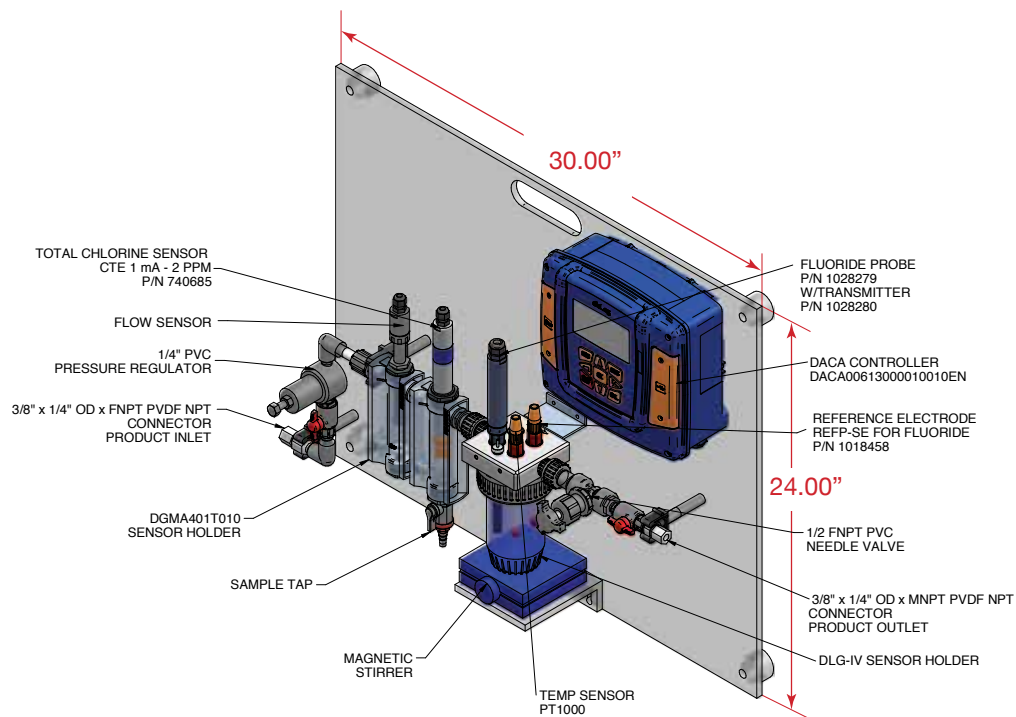

ProMinent Fluid Controls, Inc.
 136 Industry Drive • Pittsburgh, PA 15275 USA
 (412) 787-2484 • Fax: (412) 787-0704
 email: sales@prominent.us • www.prominent.us

© 2018 ProMinent Fluid Controls, Inc.
 All Rights Reserved

PN: 7750243
 ProMinent_Reagent_Free_Analyzers.indd rev0 04/10/2018



Analyzer Sample Recovery

Product Specifications

VENTURI SAMPLE RETURN SYSTEM



We recommend using Amperometric total/free chlorine probes for these Chloramine Boosting Systems as this enables the sample flowing through the analyzer to be returned back into the potable water reservoir. Being able to return this sampled water back into the potable water reservoir saves approximately 250 gallons/day of water from being wasted to a drain at the site. The Sample Recovery system utilizes a sample pump, with a sample collector and Venturi that work in conjunction to not only provide sample flow to the water quality analyzer, but also to return this sample back to the reservoir. Having a sample recovery system installed with the Chloramine Boosting System will save an estimated 91,000 gallons of potable water from being wasted to a drain at the site

PRODUCT INFORMATION

Sample pump selection will be influenced by the hydraulic profile of the tank (below grade tank to use submersible pump, above grade tank to use centrifugal pump).

Below Grade: Submersible Pump-STA Rite Pump

Above Grade: Centrifugal Pump-March Pump

- Sample pump to provide sample flow
- Sample Collector
- Venturi to return sample back to the reservoir
- Dimensions 28" w x 24" t with 3/4" PVC plumbing

VENTURI SYSTEM

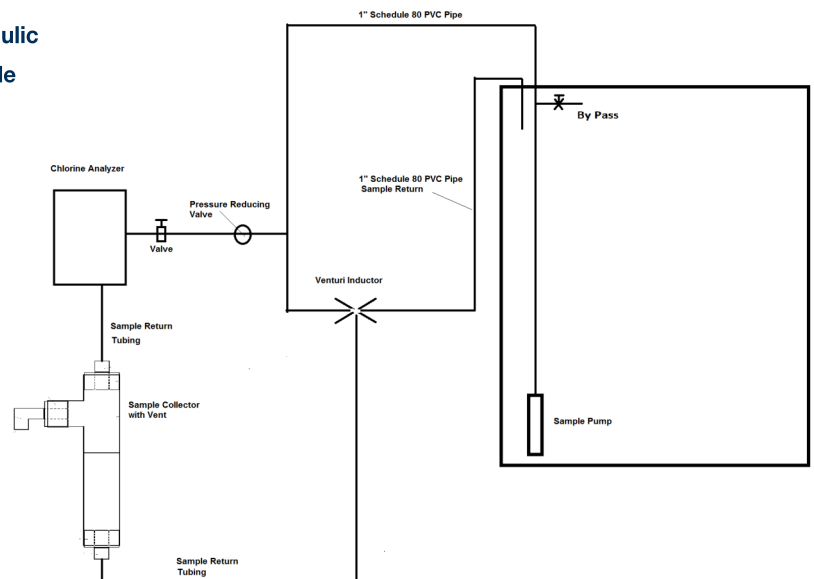

For more information call 667-BIG-WAVE

www.BIGWAVEWATER.com

MEMORANDUM

DATE: October 24, 2023

TO: Board of Directors
Temescal Valley Water District

FROM: General Manager

SUBJECT: Agreement with Riverside County Emergency Management for trailer positioning.

BACKGROUND

Riverside County Emergency Management Department has been working with the community to place an emergency equipment trailer in the Temescal Valley area. Our Water Reclamation Facility is in the center of the valley and a perfect location for emergency personnel to access the equipment during an emergency. We have room for the trailer, can provide an access code for entrance and the agreement has been reviewed by our District Counsel.

FISCAL IMPACT

N/A

RECOMMENDATION

At the discretion of the Board:

- 1. Authorize the General Manager to approve the agreement.*

Respectfully submitted,

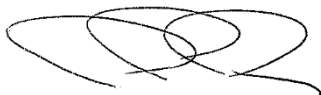

Jeff Pape
General Manager

RIVERSIDE COUNTY EMERGENCY MANAGEMENT
EQUIPMENT STORAGE AGREEMENT

This Equipment Storage Agreement (hereinafter "Agreement") is by and between the County of Riverside Emergency Management Department ("EMD") and Temescal Valley Water District ("TVWD") (collectively, "Parties").

- I. **Scope and Purpose.** The purpose of this Agreement is to accomplish equipment storage at TVWD. The Equipment shall be stored at the following location:

Department: Temescal Valley Water District
Address: 22646 Temescal Canyon Road
City, State, Zip: Corona, CA 92883

Contact Regarding Storage:

Name: Jeff Pape
Email: jeffp@TemescalVWD.com
Phone: (951) 667-6323

- II. **Term and Termination.** TVWD agrees that EMD is allowed to store the equipment identified on "Exhibit A" ("Equipment") from the date this Agreement is executed until Terminated, which may be done by either party without cause with five (5) days' advance written notice.
- III. **Notice.** Any notice provided for in this Agreement shall be in writing and shall be considered as having been delivered if hand-carried, transmitted via facsimile or email, or mailed by United States mail, postage prepaid, to the following, respectively

Name: Riverside County EMD
450 E. Alessandro Blvd.
Riverside, CA 92508
Attn: Director

Temescal Valley Water District
Name: 22646 Temescal Canyon Road
Corona, CA., 92883
Attn: General Manager

- IV. **Storage.** Upon full execution of this Agreement, the Equipment may be stored at TVWD location identified above.
- V. **Access.** Using a gate access code, EMD personnel and/or designated EMD volunteers may be authorized to access the Equipment anytime during regular TVWD business hours. Notification (Phone or Email) to the General Manager or his/her designee shall be completed before gaining access to the Equipment. During an emergency or non-business hours, EMD personnel and/or designated EMD volunteers will notify (Phone or Email) TVWD's General Manager or his/her designee prior to gaining access to the Equipment.
- VI. **Maintenance.** EMD shall maintain its Equipment in good operating condition and repair. EMD shall make all necessary replacements thereto so that the operating efficiency thereof shall at all times be maintained and preserved.
- VII. **Risk of Loss.** EMD assumes all risks of loss, damage, destruction, or interference with using the Equipment while stored on TVWD's property. EMD acknowledges that TVWD never intended nor designed the above-mentioned location to be used as a storage facility and acknowledges that TVWD does not guarantee the security of the stored property. EMD agrees to assume full responsibility for and risk of property damage due to negligence or otherwise while the Equipment is stored. TVWD accepts no responsibility for the stored Equipment or other property brought onto or left at the premises, and all liability for loss or damage is hereby excluded.
- VIII. **Use and Assumption of Risk.** EMD assumes all responsibility for the operation of the Equipment, according to manufacturer guidelines, and any risk of damage to Equipment and injury, including death, to the operator. EMD shall be responsible for training any person on the safe and proper operation of the Equipment. EMD assumes sole risk and responsibility arising out of the operation and use of the Equipment.

- IX. ***Title and Right to Possession.*** The Parties agree that title to the Equipment shall remain vested with EMD. TVWD shall not loan, transfer possession, pledge, claim the right of offset, or lien on the Equipment loaned hereunder.
- X. ***Insurance.*** During the Term, EMD shall maintain, at its expense, property and liability insurance coverage or self-insurance retentions that are, in its good faith judgment, commercially reasonable and otherwise adequate for its ownership.
- XI. ***Delivery Terms.*** EMD shall be responsible for all costs associated with the delivery and removal of the Equipment and all related documentation.
- XII. ***Rental Cost.*** No rental cost shall be assessed to TVWD for storage of the Equipment within the terms and purpose of this Agreement.
- XIII. ***Sharing of Data.*** Data obtained from using the Equipment within the terms of this Agreement shall be shared by and between the Parties. Publication credit, if any, shall be mutually determined and given as appropriate.
- XIV. ***Indemnity.*** EMD shall indemnify and hold harmless TVWD, their respective directors, officers, employees, agents, and representatives (individually and collectively hereinafter referred to as "Indemnitees") from any liability, action, claim, or damage whatsoever, based or asserted arising from the storage of the Equipment.
- XV. ***Amendments.*** This Agreement may be altered only by a written amendment signed by authorized representatives of both Parties.
- XVI. ***DISCLAIMER OF WARRANTY. THE EQUIPMENT UNDER THIS AGREEMENT IS PROVIDED WITHOUT WARRANTY OF MERCHANTABILITY OR FITNESS FOR A PARTICULAR PURPOSE OR ANY OTHER WARRANTY, EXPRESSED OR IMPLIED. IN NO EVENT IS TVWD LIABLE FOR ANY INCIDENTAL, SPECIAL, OR CONSEQUENTIAL DAMAGES, INCLUDING LOST REVENUE,***

PROFIT OR DATA, ARISING OUT OF OR RELATING TO THE USE OF OR INABILITY TO USE THE EQUIPMENT. ALL SUCH OTHER WARRANTIES ARE HEREBY DISCLAIMED.

- XVII. ***Compliance with Laws.*** EMD shall comply with all federal, state, County, and municipal laws, ordinances, and regulations, if any, applicable to the transportation and use of the Equipment. EMD shall secure all local, state, and federal licenses or permits required to use the Equipment and all taxes and fees in compliance with state and federal laws.
- XVIII. ***Counterparts.*** This Agreement may be executed in any number of counterparts, each of which will be an original, but all of which together will constitute one instrument. Each party of this Agreement agrees to the use of electronic signatures, such as digital signatures that meet the requirements of the California Uniform Electronic Transactions Act (“CUETA”) Cal. Civ. Code, §§ 1633.1 to 1633.17), for executing this Agreement. The Parties further agree that the electronic signatures of the Parties included in this Agreement are intended to authenticate this writing and to have the same force and effect as manual signatures. Electronic signature means an electronic sound, symbol, or process attached to or logically associated with an electronic record and executed or adopted by a person with the intent to sign the electronic record pursuant to the CUETA as amended from time to time. The CUETA authorizes use of an electronic signature for transactions and contracts among parties in California, including a government agency. Digital signature means an electronic identifier, created by computer, intended by the party using it to have the same force and effect as the use of a manual signature, and shall be reasonably relied upon by the Parties. For purposes of this section, a digital signature is a type of "electronic signature" as defined in subdivision (i) of Section 1633.2 of the Civil Code.
- XIX. ***Entire Agreement.*** This Agreement, including the Exhibits attached hereto, contains the entire agreement between the Parties and supersedes all prior written or oral agreements with respect to the subject matter herein.

[Signatures on following page]

IN WITNESS WHEREOF, duly authorized representatives of the Parties have signed in confirmation of this Agreement.

County of Riverside Emergency Management
Department

Temescal Valley Water District

By: _____
Bruce Barton, Director
Emergency Management Department

By: _____

Dated: _____

Dated: _____

APPROVED AS TO FORM:
MINH C. TRAN,
County Counsel

By: 
Melissa R. Cushman
Deputy County Counsel

Attachment - A

EQUIPMENT DESCRIPTION

EMD No. EM-Equip-001
 Equipment Description: White 18 Foot-enclosed trailer
 Manufacturer: AZ-TEX
 VIN: 4ZBEN21407F008345
 License Plate: 1259627
 Asset #: 07-805
 Value: \$5,730.30

TRAILER SUPPLIES

Temescal Valley CERT Trailer

Item	Vendor	Quantity	Cost (EA)	Total	PO	Notes from Verna	Updates
Triage Tarps	Global	3	\$ 192.95	\$ 578.85	23-0004427	Items arrived and are at warehouse	Verified. Items are in the warehouse 12.19.22
Generator	Grainger	3	\$ 576.40	\$ 1,729.20		12.8.22 (3) Generators received in at warehouse.	Verified. Items are in the warehouse 12.19.22
Fire Extinguisher	Global	10	\$ 60.95	\$ 609.50		Items have arrived and are at warehouse	Verified. Items are in the warehouse 12.19.22
Fire Ex. Mt. Brackets	Global	2	\$ 48.95	\$ 97.90		Items given to Erik 8/8/22	Verified. Items are in Jennifer's cubicle 12.19.22
Pry Bars Large	Grainger	10	\$ 109.57	\$ 1,095.70		Items have arrived and are at warehouse	Verified. Items are in the warehouse 12.19.22
Pry Bars Small	Grainger	10	\$ 22.70	\$ 227.00		Items have arrived and are at warehouse	Verified. Items are in the warehouse 12.19.22
Cribbing Crates	Global	1	\$ 2,696.00	\$ 2,696.00		(1) 12 piece set arrived & at the warehouse	Verified. Items are in the warehouse 12.19.22
CERT Flags	EZ-UP	6		\$ 1,056.80	EMARC-1776	9/15 - Need confirmation that flag design is correct. Eric does not have any info about this. *	Verified. Items are in the warehouse 1.26.23
Flagging Tape	Global	3	\$ 17.39	\$ 52.17		Yellow, red, white & red have arrived & are at warehouse	Verified. Items are in the warehouse 12.19.22
Splints	Grainger	3	\$ 39.48	\$ 118.44		Given to Mary 8/2/22	Verified. Items are in Jennifer's cubicle 12.19.22
Red Evacu-Aids w/ case	Grainger	6	\$ 74.88	\$ 449.28	23-0008085	Items are at the warehouse	Verified. Items are in the warehouse 12.19.22
5K lb Floor Jacks	Global	3	\$ 422.95	\$ 1,268.85		(3) 3 Ton floor jacks are at warehouse	Verified. Items are in the warehouse 12.19.22
Position Vest	Propac	50		\$ 969.75	23-0020767	12/12 - (50) Vests Ordered	Verified. Items are in the warehouse 1.26.23
				TOTAL			
				\$ 10,949.44			

October 19, 2023

Board of Directors
Temescal Valley Water District

Re: Water and Sewer Operations – September 2023

Dear Board Members:

Temescal Valley Water District operations personnel perform the following tasks on a regular and routine basis:

- Managed 305.73 acre-feet of water through system.
- Collected routine potable water samples as required by the State Water Resources Control Board, Division of Drinking Water.
- Collected routine wastewater monitoring samples as required by Regional Water Quality Control Board.
- Submitted monthly reports to the State Water Resources Control Board, Division of Drinking Water for: TVWD distribution system monitoring.
- Submitted monthly SMR reports to the Regional Water Quality Control Board for: Temescal Valley Wastewater Reclamation Facility.
- Meters read 6,672.
- 0 customers locked off.
- Responded to 74 service calls.
- Installed 5 meters for the various developers.
- Responded to 95 USA Dig Alerts to mark District underground utilities.

In addition to the above regular and routine tasks we also performed the following operational tasks.

- 0 loads of biosolids were hauled off this month.

- Shipped out empty polymer totes for recycling.
- The Treatment Plant's percolation ponds and the Wildrose Reservoir were sprayed for weed control by our contracted weed abatement company.
- Operations staff collected sludge samples with Dudek engineers for the sludge evaluation project.
- A new sludge transfer pump was installed at our aerobic digesters. This replaced an old worn out unit.
- Percolation pond maintenance work began by contractor.

Sincerely,

Paul Bishop, Superintendent

**TEMESCAL VALLEY WATER DISTRICT
ENGINEERING DEPARTMENT**

DISTRICT ENGINEER'S MONTHLY REPORT

Date: October 19, 2023
To: Jeff Pape, General Manager
From: Justin Scheidel, District Engineer
Subject: Engineering Activities Update for the Month of October 2023

The following is a summary of the status of current engineering projects:

PLAN CHECKING & DEVELOPER RELATED PROJECTS

Temescal Canyon Road Commerce Center (Rinker Property): Submitted first plan check review comments back to the developer for the onsite and offsite improvements required for the development. Currently waiting for the developer to make the required edits and provide a subsequent submittal.

Temescal Hills (Hunt and Lawson): Fourth plan check has been completed and returned to the developer. The Water and Sewer plans have been tentatively approved but the Non-Potable Water System plans are still lacking sufficient detail for approval. We are currently waiting for the developer to resubmit the Non-Potable Water Plans based on our comments.

AS-NEEDED ENGINEERING SERVICES

Status

General Engineering Initiated During FY 2023/24

- | | |
|--------------------|--|
| Project 1401.2301: | As-Needed Potable Water Engineering for FY 2023/24: Development of the district engineering report and attendance of the District's board meeting. |
| Project 1401.2302: | As-Needed Wastewater Engineering for FY 2023/24: Conducted as-built research for various projects to be designed by developers and other municipalities. Obtained as-builts from the District catalog to update the District's GIS linework and as-built reference system. |
| Project 1401.2303: | As-Needed Non-Potable Water Engineering for FY 2023/24: Conducted as-built research for various projects to be designed by developers and other municipalities. |
| Project 1401.2205: | GIS/Map Updates for FY 2023/24: We have completed our major overhaul of the District's GIS database to reflect the as-built facilities more accurately. The web based GIS system has been updated and we will begin the process of transferring all data to InfoWater which will be complete by the end of the year. |

CAPITAL IMPROVEMENT PROJECTS

Status

Project 1401.2008: DWR LAM Validation: The second batch of information provided by DWR has been reviewed, corrected, and returned to DWR for processing. We attended DWR's workshop regarding the next phase of landscape area identification for commercial properties. We are currently waiting for DWR to release the data for the District to review.

90% Complete

Project 1401.2208: Sludge Study: All sampling events have been completed and the results have been obtained and reviewed. The draft sludge study is attached to this report for Board review.

85% Complete

Project 1401.2209: Recycled Water Conversion Study: Projects 3, 4, 5, 6, 7, 8, and 9 were combined into a public bid which was awarded in July. Projects 1, 2, and 10 are currently on hold while the projects are coordinated with the property owners.

85% Complete

Project 1401.2304: Colladay Reservoir Engineering Services During Construction: The public bid opening for this project was conducted on September 19th. The notice of award has been issued to the Contractor and the pre-construction meeting is scheduled for October 26th.

Publicly Bid

Project 1401.2305: Percolation Pond Expansion Project: This project has not started yet.

Not Started

Project 1401.2306: Recycled Water Conversion Project Engineering Services During Construction: Construction has been completed on sites 4, 8, and 9. Focus has now been shifted to site 3 (the Wildrose Business Park). Once completed, construction activities will be moved to sites 4 and 5. All sites are anticipated to be completed by the end of November. We are currently notifying the affected communities and business owners of the proposed construction schedule and access limitations.

60% Complete

TECHNICAL MEMORANDUM - DRAFT

To: Jeff Pape, General Manager
Paul Bishop, Operations Superintendent

From: Greg Guillen, PhD, PE; Agata Bugala, EIT (Dudek)
Temescal Valley Water Reclamation Facility (TWWRF) Unit Process and Solids Evaluation Study

Subject: Study

Date: October 2023

Attachments: Mass balance in the Excel format to be provided to the District

Executive Summary

This technical memorandum (TM) documents the development and analysis of a high-level process evaluation conducted in 2023 at the Temescal Valley Water District (District) Water Reclamation Facility (WRF). The purpose of this study is to provide District management, engineering, and operations staff with the following information:



Temescal Valley Water Reclamation Facility

- Develop a protocol for sampling various process streams within the WRF and measuring key constituents,
- Develop a mass flow model using the sampling data to evaluate individual process performance and constituent removal, and
- Estimate future sludge characteristics, production, and dewatering capacity requirements.

Summary of Findings

The analysis found the following:

- The WRF influent wastewater is characterized as high strength
- The WRF produces high quality effluent and achieves high percent removals of key constituents
- Incomplete nitrification occasionally occurs within the sequencing batch reactors, potentially due to imbalanced loading and insufficient aeration.
- The primary clarification process achieves good BOD and TSS removal, offsetting aeration demand in the SBRs
- Volatile solids reduction occurs only within the first half of the aerobic digestion process. The existing aerobic digestion process has additional capacity to digest higher sludge loads generated by future, higher flow conditions.
- The WRF currently utilizes 3 different sludge dewatering technologies, none of which have capacity to meet future dewatering capacity requirements.

1. Introduction

Temescal Valley Water District (District) Water Reclamation Facility (WRF) contracted with Dudek to prepare an evaluation of the sludge handling process of the WRF due to several recent changes including the addition of primary clarification, expansion of sequencing batch reactors, and expansion of the aerobic digesters. These changes have resulted in reduced sludge production and less odor generation when using geotextile dewatering bags. The purpose of this study is to provide District management, engineering, and operations staff with the following information:

- Develop a protocol for measuring and sampling various streams within the WRF.
- Conduct three (3) sampling events.
- Develop a mass flow model using the sampling data to estimate future sludge production and characteristics.
- Evaluate each unit process and provide a planning-level analysis estimate of future sludge processing requirements.

Wastewater Reclamation Facility Summary

Sewage is collected and conveyed through the District gravity and forcemain system to the WRF. The WRF has a current average dry weather flow (ADWF) design capacity of 2.25 MGD, and a peak wet weather flow (PWWF) design capacity of 6.75 MGD. The WRF complies with the Waste Discharge Requirements (WDR) Order No. R8-2012-00282.

The WRF is designed to remove BOD, TSS, and nitrogen. Individual WRF processes are summarized in **Table 1**. Large objects are screened out of the raw sewage in the WRF headworks. Settleable solids are removed by the WRF primary clarifiers. Soluble BOD, nitrogen (organic nitrogen and ammonia), and suspended solids that pass through the primary clarifiers are removed in the sequencing batch (SBR) reactors. The secondary effluent undergoes tertiary treatment and disinfection before being discharged either at DP 001 Temescal Creek or at DP002 Recycled Water. This recycled water use area overlies or is tributary to the Bedford Groundwater Management Zone. Undisinfected, secondary effluent is discharged at DP 003 to an unlined pond. Additionally, sludge from the primary and secondary clarifiers is processed through aerobic digesters and dewatering through centrifuges, sludge drying beds, and/or sludge drying geotextile bags. Dewatered sludge is then hauled offsite for disposal. A schematic of the Temescal WRF system and processes are described in **Table 1** and **Figure 1**.

Table 0. WRF Unit Process and Major Equipment Summary

Process Area	Description	Key Assets
Headworks	Functions to remove rags, grit, and other large materials from the influent wastewater before entering downstream processes. Influent flows by gravity through mechanical screens located in the headworks building.	<ul style="list-style-type: none"> ▪ Headworks ▪ Mechanical screens ▪ Odor Control Scrubber
Primary Treatment	Functions to remove settleable solids and floatable scum from plant influent before entering downstream secondary process. The primary equalization (EQ) basin functions to equalize flow before it is transferred to the SBRs.	<ul style="list-style-type: none"> ▪ Primary clarifier tanks ▪ Sludge/scum collectors ▪ Primary sludge pumps ▪ Primary EQ basin
Secondary Treatment (Biological)	Functions to remove BOD, TSS, and nitrogen from the wastewater utilizing a sequencing batch reactor (SBR) process. The process is intended to operate in four cycles. It begins with filling the reactor with wastewater, followed by aeration and biological treatment, during which microorganisms break down pollutants. Settling separates solids from the treated water, which is then withdrawn, while an idle phase allows further settling. Important parameters which control biomass growth rates and microbial communities include dissolved oxygen concentration, mixed liquor suspended solids (MLSS) concentration, food-to-microorganism (F/M) ratio, sludge age (SRT), temperature, pH, nutrient levels, hydraulic retention time (HRT), influent characteristics, and oxygen transfer efficiency.	<ul style="list-style-type: none"> ▪ SBRs ▪ Diffusers ▪ Blowers
Tertiary Treatment ¹	Functions to remove turbidity and residual total suspended solids (TSS) from secondary effluent and achieve Title 22 tertiary recycled water quality standards for irrigation.	<ul style="list-style-type: none"> ▪ Continuous Backwash Sand Filters
Disinfection ¹	Functions to inactivate pathogens and bacteria in the filtered effluent using sodium hypochlorite to meet regulatory disinfection requirements.	<ul style="list-style-type: none"> ▪ Chlorine dosing and monitoring system ▪ Chlorine contact basin
Sludge Digestion	Aerobic digesters function to reduce the quantity of sludge and stabilize biosolids through volatile solids reduction.	<ul style="list-style-type: none"> ▪ Aerobic Digesters ▪ Diffusers ▪ Blowers
Sludge Dewatering and Disposal	Functions to remove water from digested sludge to increase density of solid waste that is disposed of at an offsite location and to reduce hauling costs.	<ul style="list-style-type: none"> ▪ Centrifuges ▪ Cake Conveyors ▪ Polymer Dosing system ▪ Dewatering Bags ▪ Sludge Drying Beds

Notes:

¹Unit process area was not evaluated.

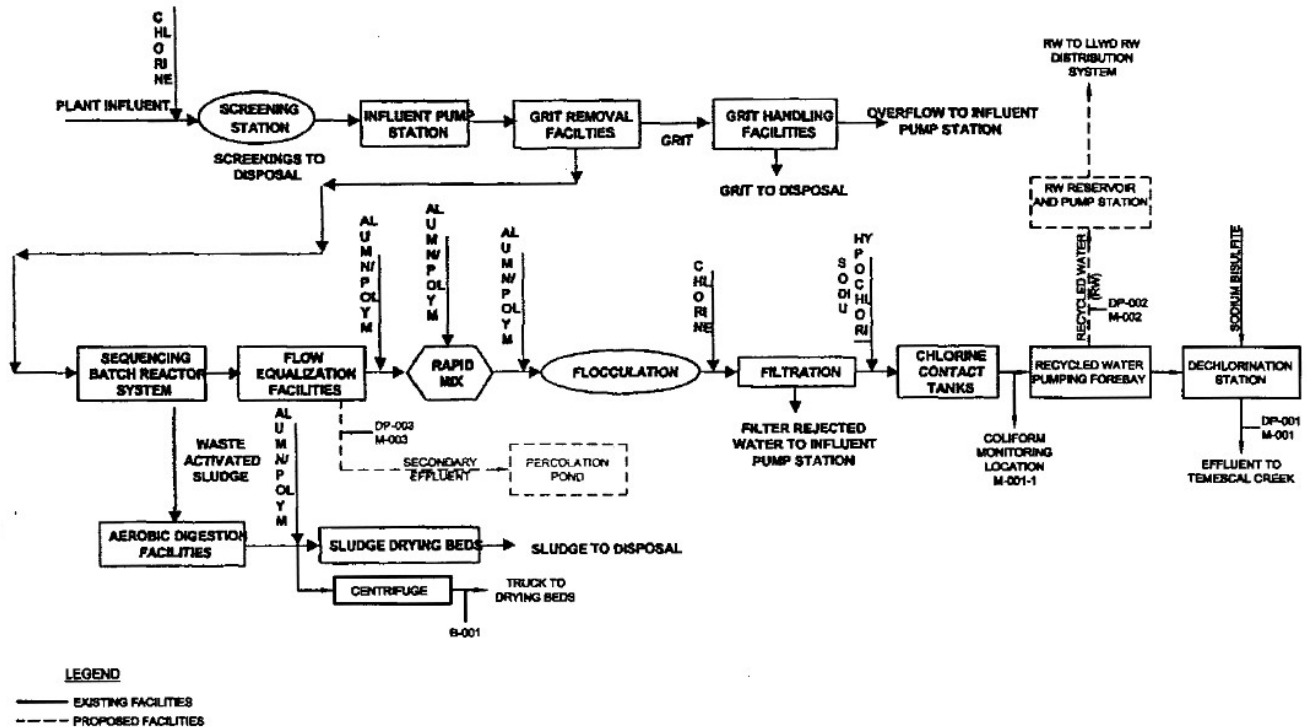

Figure 1. WRF Process Flow Diagram

2 Model Overview

The mass balance Excel model was developed to establish current baseline conditions and characteristics of the entire WRF and provide the District with a better understanding of the performance of each process with the ultimate goal of achieving efficient and reliable plant-wide compliance into the future. This required capturing samples from liquid and solid streams throughout the WRF. The model and necessary data to calibrate the model are detailed below. The model was configured and calibrated with plant physical data, operation data, influent loading data, and wastewater characteristics based on three sampling events spanning Winter through Summer of 2023.

The model evaluated mass flows and conversions for each WRF unit process. Key performance indicators (KPIs) based on water quality and operation conditions have been established to analyze and provide comparisons between each sampling event. An example of the Excel mass balance process modeling is shown in **Figure 2**. The District will be provided with mass balance in Excel form.

Sampling procedures are summarized in the following sections.

Temescal WRF DRAFT SAMPLING MASS BALANCE

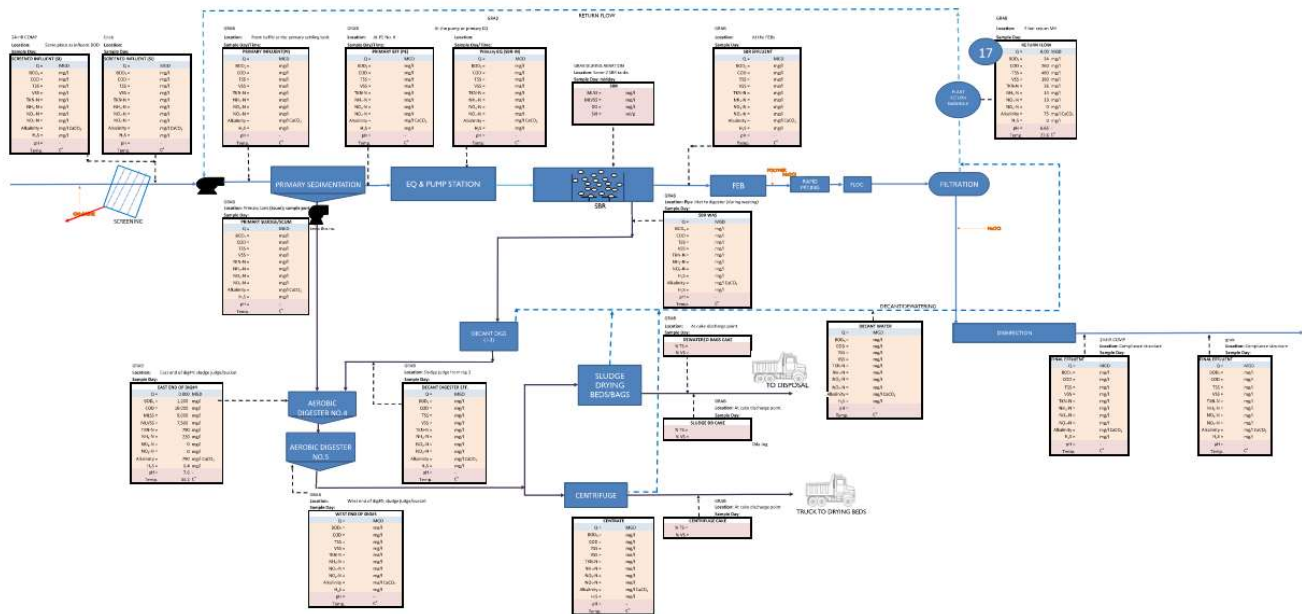

Figure 2. Mass Balance Model Example

2.1 Sampling Process

Samples were taken from 22 sampling locations. WRF influent and effluent samples were composite samples, while the remainder of the samples throughout the plant were grab samples. There were no major operational issues during the sampling events. All operational changes and notes are summarized in **Table 2**.

Table 2. List of Operational Changes During Sampling Events

Date	Operational Note/Change
2/1/2023	4-SBRI-PE was taken from Primary Effluent. There was no flow in the EQ basin.
	SBR2 and SBR8 missed aeration cycle from both SBRs. Sample taken 5 min into the settling cycle. Pulled sample when aeration was off.
	SBR9 sample was not taken due to a missed aeration cycle.
	Primary sludge was not settling after 15 min. Hach solids meter not calibrated. It showed that solids concentration is 8,600 mg/l.
	No SVI done on SBR2 and SBR8 and SBR 9.
	pH & temp meter on digester no. 4 were not calibrated.
	SBR WAS wasted from SBR 1.
	Sample from dig#3 (13-DD decant digester) was taken on Monday 2/6/23.
	Decant water (14-DW) was taken on Tuesday 1/31/23.
	Temperature measurements were not taken for all samples because the temperature probe didn't arrive on time.
5/17/2023	Centrifuge was in operation. Average centrifuge feed flow is approximately 50 gpm.
	Filters were in operation.

Date	Operational Note/Change
	pH & temp meter on Digester no. 4 were not calibrated.
	Water level in Digester No. 5 was 3.5 ft; very low so sample likely includes foam
	Centrifuge was in operation.
	pH & temp meter on Digester no. 4 were not calibrated.
9/13/2023	Centrifuge was in operation. Average centrifuge feed flow is 50 gpm.

3. WRF Process Overview

A process performance overview for the WRF is provided in **Table 3**. Average values of the data, design criteria, and typical ranges are included as applicable. Data summarized in this report were captured during three sampling events between February 2023 and September 2023.

Table 3. Process Performance Summary

Parameter	Units	Avg. WRF Value	Design Criteria	Metcalf & Eddy Typical Range	Regulatory Limit
Plant Influent					
Daily Plant Influent Flow	MGD	1.29	2.25	-	-
Influent BOD ₅	mg/l	453	-	200-400	-
Influent TSS	mg/l	517	-	195-389	-
Influent TKN	mg/l	52	-	20-75	-
Influent Ammonia-N	mg/l	38	-	12-45	-
Primary Treatment					
Primary Effluent BOD	mg/l	120	280	-	-
BOD Removal	%	38%	-	20-40	-
Primary Effluent TSS	mg/l	67	-	-	-
TSS Removal	%	57%	-	45-65	-
Primary Solids (to waste)	%	4.4	-	3	-
Primary Effluent TKN	mg/l	53	-	-	-
Ammonia Removal	%	21%	-	-	-
Secondary Treatment					
Secondary Effluent BOD	mg/l	19	20	< 20	-
Secondary Effluent TSS	mg/l	8	20	< 20	-
Secondary Effluent Ammonia-N	mg/l	4.1	-	< 3	-
Secondary Effluent Nitrate-N	mg/l	3.7	-	-	-
Secondary Effluent Nitrite-N	mg/l	1.1	-	-	-
Aerobic Digestion					
Volatile Solids Loading Rate	lb VSS/1000 ft ³ /d	26	-	100-300	-
Volatile Solids Destruction	%	42%	40%	38-50	-
Digested Sludge Production	dry-lb/d	1810	5207	-	-
Solids Dewatering					

Parameter	Units	Avg. WRF Value	Design Criteria	Metcalf & Eddy Typical Range	Regulatory Limit
Centrifuge Cake Total Solids	%	19%	20-22	-	-
Dewatering Bags Total Solids	%	14%	-	-	-
Plant Effluent					
Effluent Flow	MGD	1.22	2.25	-	2.25
Effluent BOD	mg/l	5.5	20	-	20 / 30 ¹ 30 / 45 ²
Effluent TSS	mg/l	3.5	20	-	20 / 30 ¹ 30 / 45 ²
pH	std units	6.8	-	-	6-9
Effluent TKN	mg/l	4.6	-	-	-
Effluent Ammonia-N	mg/l	3.5	-	-	-
Effluent Nitrate-N	mg/l	7.4	-	-	-
Effluent Nitrite-N	mg/l	0.2	-	-	-
Effluent Total Inorganic Nitrogen	mg/l	11	-	-	13 ³

Notes:

1. Avg. monthly / avg. weekly regulatory limits at locations DP001 and DP002, as specified in WDR Order No. R8-2012-00282
2. Avg. monthly / avg. weekly Regulatory limits at location DP 003, as specified in WDR Order No. R8-2012-00282
3. The 12-month flow weighted running average at location DP 003, as specified in WDR Order No. R8-2012-0028

Process data that are missing for each of the core unit processes have been identified as “Key Data Gaps”. Evaluating and filling these data gaps will establish initial baseline conditions and characteristics of the entire WRF and provide the District with a better understanding of the performance of each process with the ultimate goal of achieving efficient and reliable plant-wide compliance.

3.1 Influent Wastewater Characterization

WRF influent was sampled downstream of the influent screens. An autosampler collected samples every hour for 24 hours. WRF influent water quality characteristics are summarized in **Table 4**.



Figure 3. Screened Influent Auto-sampler Location

Table 4. Influent Wastewater Quality Summary

Parameter	Units	Avg. WRF Value	Metcalf and Eddy Typical Range
Daily Plant Influent Flow	mgd	1.3	-
BOD ₅	mg/l	453	200-400
	lb/d	4,813	-
COD	mg/l	983	-
TSS	mg/l	517	195-389
	lb/d	5,484	-
VSS	mg/l	497	-
	lb/d	5,272	-
TKN	mg/l	52	-
	lb/d	553	-
Ammonia (NH ₃)	mg-N/l	38	-
	lb/d	404	-
Nitrate	mg-N/l	ND ¹	-
Nitrite	mg-N/l	ND ¹	-
Alkalinity	(mg/l as CaCO ₃)	260	-
Sulfide	mg/l	ND ¹	-
pH	-	7.3	-
BOD:COD Ratio	-	0.5	-
VSS:TSS Ratio	-	0.96	-
NH ₃ -TKN Ratio	-	0.73	-

Notes:
¹ND = non-detect

Key Notes and Findings:

- Measured 24-hr composite samples.
- Influent BOD and influent TSS concentrations and loadings are high with respect to the typical municipal wastewater industry standards. These elevated loads will lead to increased sludge production.
- Nitrate, nitrite, and sulfide were not detected.

Data Gaps:

- None.

3.2 Primary Clarification

Primary influent was collected by grabbing a single sample from the common primary clarifier feed channel while primary effluent was collected by grabbing a single sample from the effluent launder of either Primary Clarifier No. 4 or No. 5. Primary sludge samples were taken from primary sludge pump No. 2. Operators opened the valve, waited approximately 3 minutes and collected a sludge grab sample. Primary clarifier characteristics are summarized in **Table 5**.



Figure 4. Primary Effluent Sampling Location

Table 5. Primary Clarification Water Quality Summary

Parameter	Units	Avg. WRF Value		
		Primary Influent	Primary Effluent	Primary Sludge
Flow	mgd	1.3	1.3	0.004
BOD ₅	mg/l	187	120	15,333
	lb/d	1,973	1,240	562
COD	mg/l	330	283	29,500
TSS	mg/l	182	67	43,667
	lb/d	1,920	703	1,584
VSS	mg/l	163	62	39,333
	lb/d	1,725	653	1,428
TKN	mg/l	67	53	603
	lb/d	722	569	23
Ammonia	mg-N/l	57	47	33
	lb/d	614	503	1.2
Nitrate	mg-N/l	ND	ND	ND
Nitrite	mg-N/l	ND	ND	ND
Alkalinity	(mg/l as CaCO ₃)	317	277	400
Sulfide	mg/l	ND	ND	0.6
pH	-	8.0	7.2	5.1
BOD:COD Ratio	-	0.5	0.4	0.5
VSS:TSS Ratio	-	0.91	0.93	0.92
NH ₃ -TKN Ratio	-	0.85	0.89	0.11

The WRF primary clarifier operational parameters are summarized in **Table 6**. The surface overflow rate and residence time presented below are for each of the primary clarifiers operated during the monitoring period. Two primary clarifiers were operated during the monitoring period.

Table 6. Primary Clarification Operating Parameters

Parameter	Units	Avg. WRF Operation	Design Criteria	Metcalf & Eddy Typical Range
Number of Clarifiers Online	#	2	3	-
Detention Time (avg)	hours	0.7	-	1.5-2.5
Side Water Depth	ft	11	-	10-16
Surface Overflow Rate (ADWF)	gpd/ft ²	389	1000 (avg) 2,000 (peak)	800-1200
TSS Removal	%	57	-	45-65
BOD Removal	%	38	-	20-40
Primary Sludge Flow	gpd	4412	-	-
Primary Sludge Thickness	%TS	4.37	-	1-6
Primary Sludge Production	dry-lb/d	1584	-	-
Primary Sludge Volatile Solids	%VS (as % of TS)	92	-	60-85

Key Notes and Findings:

- Primary influent BOD and TSS concentrations were much lower than those measured in the influent composite sample. This is likely a result of the difference in grab sampling primary clarification samples compared to composite sampling of the WRF influent.
- Primary clarifiers reduced the total BOD mass load by 733 lb/day (38%) and TSS by 1,217 lb/day (57%) which indicates good BOD and TSS removal. Typically, a primary clarifier can remove around 45-65% of the influent TSS, and 20-40% of the influent BOD.
- In primary settling tanks, the BOD:COD ratio was approximately 0.5. The typical BOD to COD ratio for domestic wastewater is between 0.4 and 0.6. The BOD to COD ratio can provide insight into the nature of the organic matter in water. If the ratio is high, it indicates that a large proportion of the organic matter is biodegradable and can be easily decomposed by bacteria. If the ratio is low, it suggests that the organic matter is less biodegradable and may require more energy and resources to remove from the water.
- TS% in primary sludge was about 4.3%.
- Slightly acidic pH in primary sludge caused septic conditions, yielding a sulfide concentration of 0.6 mg/l.
- The primary clarifiers are under loaded with respect to the designed surface overflow rate and typical industry ranges.

3.3 SBRs and SBR Effluent

SBR samples were collected during the aeration cycle by obtaining single samples from the top of SBRs 1, 3, 8, 9, and 10. Solids and SVI analyses were conducted on these samples, which were collected approximately 30 to 40 minutes apart. The SBR effluent samples were obtained from a common SBR effluent header. SBR waste activated sludge (WAS) samples were collected approximately 5 minutes after the start of wasting from the inlet pipe of Digester No. 3.



Figure 5. SBR Basin Sampling Location

The SBR wastewater characteristics are summarized in **Table 7**.

Table 7. SBR Water Quality Summary

Parameter	Units	Avg. WRF Value			
		Primary Effluent/Secondary Influent	SBRs	Secondary Effluent	WAS
Flow	mgd	1.3	-	1.1	0.035
BOD ₅	mg/l	120	-	19	1,887
	lb/d	1,240	-	173	498
COD	mg/l	283	-	50	4,300
TSS/MLSS	mg/l	67	1,831	8	4,867
	lb/d	703	3,946	69	1,399
VSS/MLVSS	mg/l	62	1,524	7	4,267
	lb/d	653	3,269	63	1,232
SVI	ml/g	-	134	-	-
TKN	mg-N/L	53	-	6.2	423
	lb/d	569	-	57	121
Ammonia	mg-N/L	47	-	4.1	9.3
	lb/d	503	-	38	2
Nitrate	mg-N/L	ND	-	3.7	ND
		ND	-	34	ND
Nitrite	mg-N/l	ND	-	1.1	ND
		ND	-	10	ND
Dissolved Oxygen	mg/l	-	4.2	-	-
Alkalinity	(mg/l as CaCO ₃)	277	-	-	200
Sulfide	mg/l	ND	-	ND	0.1
pH	-	7.2	6.8	6.9	6.8
BOD:COD Ratio	-	0.93	-	0.40	0.63
VSS:TSS Ratio	-	0.93	0.83	0.96	0.87
NH3:TKN Ratio	-	0.89	-	0.54	0.02

Biological treatment operational parameters are summarized in **Table 8**.

Table 8. SBR Operating Parameters

Parameter	Units	Avg. WRF Operation	Design Criteria	Metcalf & Eddy Typical Range
Number of SBRs Online	#	6 of 10	10 of 10	-
Influent BOD Concentration	mg/l	120	280	-
Influent BOD Loading Rate	lb/d	1,529	2,627	-
Influent TKN	mg/l	56	62 (avg) ² 80 (peak)	-
MLSS Concentration	mg/l	1,831	3,500 ¹	2,000-5,000
MLSS Volatile Content	%	83%	-	-
SVI	ml/g	137	-	-
Dissolved Oxygen	mg/l	4.2	-	-
Detention Time	h	16	19.4 ¹	15-40
MCRT	d	8	11.9 ¹	15-30
F:M Ratio	lb BOD/lb MLSS/d	0.11	0.10 ¹	0.04-0.1
SBR Waste Sludge Production	dry-lb/d	1,399	-	-
Effluent TSS	mg/l	7.7	20 ²	-
Effluent BOD	mg/l	19	20 ²	< 30
Effluent Ammonia	mg/l	4.1	-	-
Effluent Nitrate	mg/l	3.7	-	-
Effluent Nitrite	mg/l	1.1	-	-
Effluent Total Nitrogen	mg/l	11	-	-

Notes:

¹ Based on Parkson cutsheet provided by the District

² Based on TVWD Water Reclamation Facility Phase IV Treatment Plant Expansion drawings

Key Notes and Findings:

- Secondary effluent meets all discharge permit requirements

Nitrogen Loading and Removal Rates

- SBRs reduced ammonia (NH₃) mass load by 465 lb/day (93%) and TKN by 513 lb/day (90%) which indicates good NH₃ and TKN removal.
- High constituent concentrations in the WAS stream are a result of the high concentration of these constituents within the activated sludge microorganisms. Concentration of SBR WAS TKN is 423 mg/l (121 lb/d) and ammonia is 9.3 mg/l (2 lb/d). A high TKN concentration in an SBR WAS stream can potentially occur due to the presence of organic nitrogen compounds in the influent, such as proteins and amino acids, which are hydrolyzed and converted to TKN during the treatment process. However, the ammonia-N



Figure 6. Waste Activated Sludge Sampling Location

fraction may be low due to nitrification and denitrification processes that occur in the treatment process, which convert ammonia-N to nitrate and nitrogen gas, respectively.

BOD and TSS/VSS Loading and Removal Rates:

- Average sampled SVI was 135 mL/g which is in the well settling sludge range. SVI above 150 mL/g typically indicate poor settleability which is caused by non-ideal floc growth.
- SBRs reduced the total BOD mass load by 1067 lb/day (86%) which indicates good BOD removal. It is unlikely that an SBR can completely remove BOD during the treatment process.
- Average MLSS is 1,831 mg/l (3,946 lb/d) which is below the design criteria of 3,500 mg/l.
- TSS removal rate in SBRs is ~ 633 lbs/d (91%).
- Average SBR wasting rate was 1,399 lb/d.
- The SBR food-to-microorganism ratio (F/M) describes the relative mass of BOD supplied to the population of activated sludge microorganisms residing in the SBRs. The average F/M value at the WRF is within the design parameters and typical industry ranges.

Data Gaps:

- None

3.5 Decant Digester

Plant operators collected a grab sample from the decant digester during the wasting process. The plant operator opened the valve and ran the sludge for a few minutes before taking the sample. Decant water is recycled back to the headworks for retreatment. Grab samples were taken on Tuesdays by plant operators. The digester decant characteristics are summarized in **Table 9**

Table 9. Digester Decant Water Quality Summary

Parameter	Units	Avg. WRF Value	
		Digester	Decant Water
Flow	mgd	0.017	0.018
BOD ₅	mg/l	3,300	493
	lb/d	440	82
COD	mg/l	9,400	90
TSS	mg/l	9,450	14
	lb/d	1,279	2
VSS	mg/l	8,650	14
	lb/d	1,172	2
TKN	mg-N/l	870	86
	lb/d	116	14
Ammonia	mg-N/l	103	27
	lb/d	14	4.5

Parameter	Units	Avg. WRF Value	
		Digester	Decant Water
Nitrate	mg-N/l	ND	ND
	lb/d	-	-
Nitrite	mg-N/l	ND	1.5
	lb/d	-	0.2
Alkalinity	(mg/l as CaCO ₃)	465	225
Sulfide	mg/l	0.3	0.1
pH	-	-	-
BOD:COD Ratio	-	0.24	0.84
VSS:TSS Ratio	-	0.92	0.97
NH ₃ :TKN Ratio	-	0.12	0.51

Decant Digester Key Notes and Findings

Nitrogen Loading and Removal Rates

- Concentration of TKN is 870 mg/l (116 lb/d) and ammonia is 103 mg/l (14 lb/d). A high TKN concentration in the decant digester suggests that there is a significant amount of organic nitrogen (e.g. protein) within the cells of the waste activated sludge.
- Nitrate and nitrite are not present in the decant digester samples.

BOD and TSS/VSS Loading and Removal Rates

- BOD concentration of 3,300 mg/l (440 lb/d).
- The decant digester thickens WAS from 4,867 mg/l TSS to 9,450 mg/l TSS, a factor of nearly two.
- VSS reduction in the decant digester is negligible (<5%).

Data Gaps

- Decant digester and decant water pH
- Decant digester dissolved oxygen

3.7 Aerobic Digestion

Thickened WAS and primary sludge are pumped to Digester No. 4 for further treatment. Digester No. 4 grab samples were taken from the east end of Digester No. 4 while Digester No. 5 samples were taken from the west end of Digester No. 5 using a bucket. Digester No. 4 and No. 5 characteristics are summarized in **Table 10**.



Figure 7. Digester No. 4 Sampling Location

Table 10. Aerobic Digester Water Quality Summary

Parameter	Units	Avg. WRF Value		
		Digester Feed	Digester No.4	Digester No.5
Flow	mgd	0.022	0.022	0.022
DO	mg/l	-	0.28	0.23
BOD ₅	mg/l	5,500	1,833	1,400
	lb/d	1,002	334	254
COD	mg/l	13,460	11,000	18,500
TSS	mg/l	15,720	9,400	13,333
	lb/d	2,863	1,810	2,477
VSS	mg/l	14,274	7,850	11,100
	lb/d	2,600	1,511	2,058
TKN	mg-N/L	764	512	850
	lb/d	139	98	156
Ammonia	mg-N/L	82	76	35
	lb/d	15	15	7
Nitrate	mg-N/L	ND	ND	21
	lb/d	-	-	3.4
Nitrite	mg-N/L	ND	ND	ND
	lb/d	-	-	-
Alkalinity	(mg/l as CaCO ₃)	411	567	283
Sulfide	mg/l	0.3	0.2	0.1
pH	-	-	7.3	6.9
BOD:COD Ratio	-	0.41	0.17	0.08
VSS:TSS Ratio	-	0.91	0.84	0.84
NH ₃ :TKN Ratio	-	0.11	0.10	0.04

Aerobic digester operational parameters are summarized in **Table 11**.

Table 11. Aerobic Digestion Operating Parameters

Parameter	Units	Avg. WRF Operation		Design Criteria	Metcalf & Eddy Typical Range
		Digester No.4	Digester No.5		
Number of Digesters	#	1 of 1	1 of 1	-	-
SRT	d	20	20	25	20-40
Temperature	°F	98	87	-	85-100
Dissolved Oxygen	mg/l	0.3	0.2	-	1-2
Volatile Solids Loading Rate	lb VSS/1000 ft ³ /d	45	26	-	100-300
Volatile Solids Destruction	%	42%	0%	40	38-50
Digested Sludge Thickness	%TS	0.9	1.3	1-3	-
Digested Sludge Production	dry-lb/d	1,810	2,477	5,207	-
	gal/wk	109,200	109,200	-	-

Key Notes and Findings

- All volatile solids destruction occurs within Digester No. 4 (42%). There is no additional volatile solids destruction in Digester No.5.
- The large digesters are underloaded with respect to volatile solids. It appears that the digesters have additional capacity for higher sludge loading.
- Hydrogen sulfide is present in digester feed sludge and persists within both digesters although no smell or excess foaming was observed during sampling.
- Alkalinity decreased from 567 mg/l as CaCO₃ in Digester No. 4 to 283 mg/l as CaCO₃ in Digester No.5 likely due to nitrification of ammonia. The decrease in alkalinity caused a slight decrease in pH between Digester No. 4 and Digester No. 5.

Data Gaps

- None

3.8 Sludge Dewatering

Aerobically digested sludge stored in Digester No. 5 is pumped either into a centrifuge, dewatering bags, or dewatering beds. The WRF has a single centrifuge that is currently operated for 6-8 hours per day, once a week. Sludge is dosed with polymer before entering the centrifuge. Centrate is returned to the headworks for retreatment. The dewatered cake is hauled offsite for disposal.

Sludge dewatering operational parameters are summarized below.



Figure 8. Dewatering Bags Sampling Location

Table 12. Centrifuge Sludge Dewatering Operating Parameters

Parameter	Units	Avg. WRF Operation	Design Criteria	Metcalf & Eddy Typical Range
Number of Centrifuges	#	1 of 1	-	-
Dewatering Schedule	h/d	6 (Mon-Fri)	-	-
	h/week	6	30	-
Feed Sludge Concentration	%	1.3	1-3	3-6
Feed Sludge Rate (Volume)	gpm	50	60	-
	gal/wk	18,000	108,000	-
Feed Sludge Rate (Mass)	dry-lb/d	2,252	2,200	-
Centrifuge Cake Solids	%TS	19	20-22	10-35
Centrifuge Cake Volatile Solids	%VS (as % of TS)	80	-	-
Solids Capture	%	98	-	90+
Current Cake Production	wet-ton/week	6	30-33	-

A dewatering bag was opened on 4/18/23 (Tuesday) and a grab sample was taken from the bag on 4/19/23 (Wednesday). This bag had held solids for approximately 6 months prior to opening and sampling. Polymer was added to the digested sludge as it was pumped to the dewatering bag. The geotextile bags are typically stored on-site in two different sizes: 100 ft long x 20 ft diameter or 50 ft x 16 ft. The larger bags can hold a maximum of 3.78 cubic yards per foot of length. Bags at the WRF are typically filled over the course of a few weeks and then allowed to dewater while a different bag is filled with digested sludge. The bags are alternately filled with sludge over the course of 2-4 months before being allowed to dewater further for an additional 2 months. In total, it takes approximately 4 to 6 months to fill and dewater using the larger bags, depending on the weather.

Table 13. Dewatering Bags Operating Parameters

Parameter	Units	Avg. WRF Operation	Design Criteria	Metcalf & Eddy Typical Range
Number of Bags	#	2 of 4	-	-
Dewatering Bag Use	no/yr	4	-	-
Dewatering Bag Capacity	yards, ea	378	-	-
	yards, total	1,512	-	-
Dewatering Time	months	4-6	-	-
Dewatering Bag Cake Solids	%	14	-	-
Dewatering Bag Volatile Solids	%VS (as % of TS)	74	-	-
Cake Production	wet-ton/yr	1,429	-	-
	dry-ton/yr	200	-	-

Digested sludge can also be wasted to the sludge drying beds during dry weather months. The sludge is allowed to settle before water is siphoned off the top. Decanted water is sent to the headworks via the plant drainage system. Water that passes through the sand and gravel layer enters the same drainage system. A wide range of cake dryness is achievable using the drying beds, but performance is largely tied to weather conditions over the course of the drying period.

Table 14. Sludge Drying Beds Operating Parameters

Parameter	Units	Avg. WRF Operation	Design Criteria	Metcalf & Eddy Typical Range
Number of Beds	#	4 of 4	-	-
Bed Volume	gal, ea	72,650	-	-
	gal, total	290,598	-	-
Dewatering Time	months	2-4	-	-
Drying Beds Cake Solids	%	85%	-	-

Key Notes and Findings

- Centrifuge feed sludge solids content is shown in **Table 14**. Aerobically digested sludge solids content is 1.3%. The average aerobically digested sludge solids content is below the design criteria of 2.4% and below the typical solids content of aerobically digested sludge.
- The current weekly digested sludge production volume is greater than the weekly design capacity of the centrifuge.
- The centrifuge produces dewatered cake at approximately 19% dry solids content while dewatered bags produce dewatered cake at approximately 14%. Centrifuge performance is within the expected range for centrifuge dewatered sludge.
- Dewatering bags are an important weather-resilient sludge dewatering strategy but require a large surface and access for heavy machinery to open the bags and spread the sludge. Odor problems have occurred in the past when opening bags that have gone septic.
- The sludge drying beds offer a redundant dewatering option, particularly in warm and dry months. High percent solids cake is achievable if the sludge is turned regularly and does not receive any precipitation.

3.9 Plant Return Water

Return water is typically a combination of digester decant water, backwash filtration, and dewatered bag drainage, which is sent back to the headworks for retreatment. The measurement of the return water involved taking a grab sample from a manhole. Wastewater characteristics are summarized in **Table 15** below.



Figure 9. Return Water Sampling Location

Table 15. Plant Return Water Quality Summary

Parameter	Units	Avg. TVWRF Value
Flow	mgd	0.1
BOD ₅	mg/l	14
	lb/d	12
COD	mg/l	142
TSS	mg/l	167
	lb/d	139
VSS	mg/l	67
	lb/d	56
TKN	mg-N/L	43
	lb/d	43
Ammonia	mg-N/L	38
	lb/d	32
Nitrate	mg-N/L	13
	lb/d	11
Nitrite	mg-N/L	0
	lb/d	0
Sulfide	mg/l	ND
Alkalinity	(mg/l as CaCO ₃)	185
pH	-	7.18
BOD:COD Ratio	-	0.15
VSS:TSS Ratio	-	0.70
NH ₃ :TKN Ratio	-	0.62

Key Notes and Findings

- The flow is an assumed value
- Constituent loads within the return water represent small loads relative to WRF influent loading

Data Gaps

- Metered flow rate

3.10 Final Effluent

Final effluent is either distributed to local customers as recycled water or discharged to the nearby creek. The District is limited on the amount and quality of recycled water it can serve. The final effluent samples were 24-hour composite samples. WRF final effluent characteristics are summarized in **Table 16**.



Figure 10. Final Effluent Sampling Location

Table 17. Final Effluent Water Quality Summary

Parameter	Units	Avg. WRF Value	Design Criteria	Metcalf & Eddy Typical Range	Regulatory Limit
Flow	MGD	1.22	2.25	-	1.58
BOD	mg/l	5	20	30 / 45	20 / 30 ¹ 30 / 45 ²
	lb/d	56	-	-	-
	% Removal	99	-	-	85
TSS	mg/L	3.5	20	30 / 45	20 / 30 ¹ 30 / 45 ²
	lb/d	36	-	-	-
	% Removal	99	-	-	85
TKN	mg/L	4.6	-	-	-
	lb/d	45.6	-	-	-
	% Removal	93%	-	-	-
Ammonia-N	mg/L	3.5	-	-	-
	lb/d	35.0	-	-	-
	% Removal	90	-	-	-
Nitrite-N	mg-N/L	0.2	-	-	-
Nitrate-N	mg-N/L	7.4	-	-	-
Effluent Total Inorganic Nitrogen	mg/L	11	-	-	13 ³
pH	std units	6.8	-	-	6.5-8.5
BOD:COD Ratio	-	0.2	-	-	-
VSS:TSS Ratio	-	0.8	-	-	-
NH3:TKN Ratio	-	0.5	-	-	-

Notes:

¹Avg. monthly, avg. weekly at DP 001 and DP002, WDR Order No. R8-2012-0028

²Avg. monthly, avg. weekly at DP 003, WDR Order No. R8-2012-0028

³The 12-month flow weighted running avg. TIN concentration shall not exceed 13mg/l at DP 003, WDR Order No. R8-2012-0028

Key Notes and Findings

- Overall, WRF influent BOD mass load was reduced by (99%), TSS by (99%), TKN by (93%), and ammonia by (90%).
- Final effluent BOD, TSS, and nitrogen are well below the regulatory limits imposed by the District's WDR.
- There is no sulfide present in the final effluent.

Data Gaps

- None

4. Estimates of Future Sludge Production and Characteristics

The WRF is currently treating approximately 1.29 MGD of primarily domestic wastewater with BOD and TSS loads listed in **Table 4**. Current WRF operation converts those loads into two sludge streams: primary sludge and waste activated sludge. The primary clarifiers remove approximately 38% of BOD and 57% of TSS and produce around 1,584 lb/d of primary sludge (4,000 gpd at 4.3% solids). Primary effluent is treated by the SBRs, which in turn produce approximately 1,400 lb/d of waste activated sludge (35,000 gpd at 4,900 mg/l TSS).

Primary sludge is wasted directly to the aerobic digesters. Waste activated sludge is thickened up to 0.9% solids before being introduced to the aerobic digesters. The current combined volatile solids loading on the aerobic digesters is 2,600 lb/d. Digester 4 reduces volatile solids by 42%. Digester 5 a negligible amount of VSS reduction for an overall VSS reduction of 42%. The digestion process currently produces 2,477 dry-lb/d of digested sludge (22,000 gpd at 1.3% solids).

Extrapolating the current digested sludge production to a future sludge production requires the following assumptions are justified and validated:

Assumption: Future influent wastewater will have similar characteristics as current wastewater.

Justification: No major industrial development is planned in the WRF collection system area. Future flows and loads will originate from primarily residential development.

Assumption: BOD and TSS removal rates in the primary clarifiers will remain similar in the future.

Justification: The WRF currently utilizes 2 of 3 primary clarifiers. Future flow conditions will likely require operation of the third primary clarifier to maintain current removal rates.

Assumption: The aerobic digestion process will provide similar rates of volatile solids reduction in the future.

Justification: Volatile solids reduction appears to be complete by the end of Digester 4 under current conditions. Future higher flow and loading conditions will require Digester 5 to be operated in a manner to achieve similar VSS reduction rates as are achieved under current conditions.

A future flow of 2.25 MGD, given the above assumptions, would be expected to yield 4,300 dry-lb/d (785 dry-ton/yr) of digested sludge (40,000 gpd and 280,000 gal/week at 1.3% solids). The existing centrifuge has a maximum capacity of 60 gpm or 108,000 gal/wk operating 30 hours per week and would only have capacity to dewater less

than 40% of the digested sludge produced at a future flow/load of 2.25 MGD. Four large dewatering bags are currently used per year to produce 200 dry-tons per year of cake. The District would need to use 16 of these dewatering bags to dewater 100% of the future sludge production. The weekly sludge production at 2.25 MGD would fill all four sludge drying beds over the course of a month. Although the WRF has multiple dewatering options at its disposal, the District cannot rely solely on any one of their current dewatering procedures for dewatering sludge at this future condition.

5. Conclusions and Recommendations

A high-level process evaluation was completed on the District's WRF. The sampling results and model development provide the District with a baseline condition against which future conditions may be compared. Overall, the WRF is providing very good wastewater treatment considering the high influent loads that were measured during this project. The combination of primary clarification and equalization, operating the SBRs to achieve nutrient removal, and large aerobic digesters allow the WRF to reliably produce high quality effluent and sludge.

The following recommendations are based on the key findings of this TM:

- Conduct an annual update to key water quality parameters measured in this project
- Use this TM and the attached Excel model to compare water quality parameters during plant upsets
- Consider more frequent monitoring of nitrogen species (ammonia, nitrate, nitrite) in the SBRs so that process changes can be made to avoid formation of nitrite
- BOD:COD ratios are reported throughout this TM. Future BOD measurements may be replaced with on-site COD measurements. COD field measurements can be correlated back to a BOD concentration using the BOD:COD ratios shown in this TM.
- The District should consider expansion of mechanical dewatering capacity

MEMORANDUM

DATE: October 19, 2023
TO: Board of Directors
Temescal Valley Water District
FROM: District Engineer
SUBJECT: Recycled Water Conversion Project Progress Payment No. 1

BACKGROUND

The District approved award of the Recycled Water Conversion Project to Weka Inc. with a contract amount of \$783,063.00.

<u>Project Summary</u>	
Contract	\$783,063.00
Change Orders Requested to Date	\$0.00
Current Contract Amount	\$783,063.00
Earned this Period	\$325,528.20
5% Retention	\$16,276.41
Earned Less Retention	\$309,251.79
Due Contractor	\$309,251.79

RECOMMENDATION

This pay estimate has been reviewed by the field inspector, and reviewed and signed by both the District Engineer and the General Manager It is recommended that the Board of Directors:

1. Authorize the payment of \$325,528.20 of which \$309,251.79 is issued to the contractor and \$16,276.41 is held in retention.

Respectfully submitted,



Justin Scheidel
District Engineer

WEKA, Inc.

TO:

Temescal Valley Water District
22646 Temescal Canyon Rd.
Corona, CA 92883

Invoice # 306-001.2

Contract Date 7/13/2023

INV DATE	JOB NAME/NUMBER	Terms
10/13/2023	306 - TVWD 2023 Non Potable Water Conversion Project	Net 30

DESCRIPTION	
	General Items = \$ 36,303.00
	Wildrose Business Park Conversion = \$ 21,862.10
	Wildrose Community Park Conversion = \$ 67,189.80
	Wildrose Ranch HOA Conversion = \$ 67,807.85
	Sycamore Creek Community Park Conversion = \$ 12,683.45
	Sycamore Creek Fire Station Conversion = \$ 44,783.00
	Sycamore Creek HOA Conversion = \$ 74,899.00
	Progress Billing No. 001.2 = \$ 325,528.20
	Retention (5%) = \$ (16,276.41)
REMIT TO:	WEKA, INC. 236 W. Orange Show Rd., Suite 114 San Bernardino, CA 92408
TOTAL AMOUNT DUE THIS INVOICE	
	\$ 309,251.79

Partial Payment Form

Temescal Valley Water District
22646 Temescal Canyon Road, Corona, CA 92883-5015
(951) 277-1414

Partial Payment Estimate #001.2

Name of Contractor: Weka, Inc.		
Name of Owner: Temescal Valley Water District		
Date of Completion:	Amount of Contract:	Dates Of Estimate:
Original: 9/21/2023	Original: \$783,063.00	Original: 10/13/2023
Revised:	Revised:	Revised:

Description of Job: **2023 NON-POTABLE WATER CONVERSION**

Item #	Contract Items Description	Contract Items			This Period		Total to Date	
		Quantity	Unit Price	Total	Quantity	Amount	Quantity	Amount
1	General Requirements	1	\$ 6,903.00	\$ 6,903.00	1	\$ 6,903.00	1	\$ 6,903.00
2	Mobilization / Demobilization	1	\$ 35,000.00	\$ 35,000.00	80%	\$ 28,000.00	80%	\$ 28,000.00
3	Excavation Safety Measures	1	\$ 2,800.00	\$ 2,800.00	50%	\$ 1,400.00	50%	\$ 1,400.00
4.01	Furnish 2" Temp Blow-Off Assembly Per Std WB-05	1	\$ 3,105.00	\$ 3,105.00	65%	\$ 2,018.25	65%	\$ 2,018.25
4.03	Furnish 4" Isolation Valve Per Std W-25	3	\$ 1,452.00	\$ 4,356.00	65%	\$ 2,831.40	65%	\$ 2,831.40
4.05	Furnish 8" 20 Foot Long Sleeve To Be Installed Where Recycled Line Passes Under Sewer Line.	3	\$ 602.00	\$ 1,806.00	65%	\$ 1,173.90	65%	\$ 1,173.90
4.08	Furnish Connection To Ex RW Line Per Detail 1 D-2	1	\$ 4,316.00	\$ 4,316.00	65%	\$ 2,805.40	65%	\$ 2,805.40
4.16	Furnish 4" Restrained TEE	1	\$ 556.00	\$ 556.00	65%	\$ 361.40	65%	\$ 361.40
4.18	Furnish 1" Proposed Service Per Std W-7 (Plastic Coated Soft Copper)	6	\$ 1,211.00	\$ 7,266.00	65%	\$ 4,722.90	65%	\$ 4,722.90
4.2	Furnish Ex Irrigation Meter With Backflow Assembly - Remove & Replace Per Detail 2 & 3 On D-2 After New Service Is Established	6	\$ 885.00	\$ 5,310.00	65%	\$ 3,451.50	65%	\$ 3,451.50
4.26	Furnish 4" DR 14 C900 PVC Recycled Water Line	629	\$ 11.00	\$ 6,919.00	65%	\$ 4,497.35	65%	\$ 4,497.35
5.01	Furnish 2" Recycled Water Service Per Std W-8 (Plastic Coated Soft Copper)	168	\$ 46.00	\$ 7,728.00	168	\$ 7,728.00	168	\$ 7,728.00
5.02	Install 2" Recycled Water Service Per Std W-8 (Plastic Coated Soft Copper)	168	\$ 347.00	\$ 58,296.00	168	\$ 58,296.00	168	\$ 58,296.00
5.03	Install 2" 90° Elbow	2	\$ 228.00	\$ 456.00	2	\$ 456.00	2	\$ 456.00
5.04	Furnish Ex Irrigation Meter With Backflow Assembly - Remove & Replace Per Detail 2 & 3 On D-2 After New Service Is Established	1	\$ 1,080.00	\$ 1,080.00	65%	\$ 702.00	65%	\$ 702.00
5.11	Furnish Cap Ex 2" Water Service At Sidewalk	1	\$ 12.00	\$ 12.00	65%	\$ 7.80	65%	\$ 7.80
6.01	Furnish 2" Recycled Water Service Per Std W-8 (Plastic Coated Soft Copper)	78	\$ 59.00	\$ 4,602.00	78	\$ 4,602.00	78	\$ 4,602.00
6.02	Install 2" Recycled Water Service Per Std W-8 (Plastic Coated Soft Copper)	78	\$ 419.00	\$ 32,682.00	78	\$ 32,682.00	78	\$ 32,682.00
6.03	Install 2" 90° Elbow	1	\$ 228.00	\$ 228.00	1	\$ 228.00	1	\$ 228.00
6.04	Furnish Ex Irrigation Meter With Backflow Assembly - Remove & Replace Per Detail 2 & 3 On D-2 After New Service Is Established	1	\$ 874.00	\$ 874.00	65%	\$ 568.10	65%	\$ 568.10
6.1	Furnish Cap Ex 2" Water Service At Sidewalk	1	\$ 12.00	\$ 12.00	65%	\$ 7.80	65%	\$ 7.80
6.14	Furnish 2" Ball Valve	3	\$ 437.00	\$ 1,311.00	65%	\$ 852.15	65%	\$ 852.15
6.16	Furnish Irrigation Booster Pump Within Stainless Steel Enclosure Per Pump Detail On D-1	1	\$ 42,832.00	\$ 42,832.00	65%	\$ 27,840.80	65%	\$ 27,840.80
6.18	Furnish 2" Conduit From Ex Cabinet To Proposed Booster Pump	20	\$ 79.00	\$ 1,580.00	65%	\$ 1,027.00	65%	\$ 1,027.00
7.01	Furnish 4" C900 DR14 PVC Pipe	862	\$ 12.00	\$ 10,344.00	65%	\$ 6,723.60	65%	\$ 6,723.60
7.03	Furnish 2" Manual Air Valve Per Std WA-01	1	\$ 2,861.00	\$ 2,861.00	65%	\$ 1,859.65	65%	\$ 1,859.65
7.05	Furnish 1" Water Service Lateral (70' Lat)	1	\$ 2,193.00	\$ 2,193.00	65%	\$ 1,425.45	65%	\$ 1,425.45

7.07	Furnish 2" Blowoff Per Std WB-01	1	\$ 2,751.00	\$ 2,751.00	65%	\$ 1,788.15	65%	\$ 1,788.15
7.1	Furnish Connection To Ex RW Line Per Detail 1 D-1	1	\$ 284.00	\$ 284.00	65%	\$ 184.60	65%	\$ 184.60
7.19	Furnish Ex Irrigation Meter With Backflow Assembly - Remove & Replace Per Detail 2 & 3 On D-2 After New Service Is Established	1	\$ 1,080.00	\$ 1,080.00	65%	\$ 702.00	65%	\$ 702.00
8.01	Furnish Ex Irrigation Meter With Backflow Assembly - Remove & Replace Per Detail 2 & 3 On D-2 After New Service Is Established	1	\$ 1,080.00	\$ 1,080.00	65%	\$ 702.00	65%	\$ 702.00
8.07	Furnish 2" Recycled Water Service Per Std W-8 (Plastic Coated Soft Copper)	70	\$ 62.00	\$ 4,340.00	70	\$ 4,340.00	70	\$ 4,340.00
8.08	Install 2" Recycled Water Service Per Std W-8 (Plastic Coated Soft Copper)	70	\$ 512.00	\$ 35,840.00	70	\$ 35,840.00	70	\$ 35,840.00
8.09	Connection To Ex 6" RW	1	\$ 3,659.00	\$ 3,659.00	1	\$ 3,659.00	1	\$ 3,659.00
8.1	Furnish Cap Ex 2" Water Service At Sidewalk	1	\$ 12.00	\$ 12.00	1	\$ 12.00	1	\$ 12.00
8.11	Cap Ex 2" Water Service At Sidewalk	1	\$ 230.00	\$ 230.00	1	\$ 230.00	1	\$ 230.00
9.01	Furnish 2" Recycled Water Service Per Std W-8 (Plastic Coated Soft Copper)	232	\$ 41.00	\$ 9,512.00	232	\$ 9,512.00	232	\$ 9,512.00
9.02	Install 2" Recycled Water Service Per Std W-8 (Plastic Coated Soft Copper)	232	\$ 262.00	\$ 60,784.00	232	\$ 60,784.00	232	\$ 60,784.00
9.03	Furnish Ex Irrigation Meter With Backflow Assembly - Remove & Replace Per Detail 2 & 3 On D-2 After New Service Is Established	1	\$ 1,080.00	\$ 1,080.00	65%	\$ 702.00	65%	\$ 702.00
9.09	Furnish Cap Ex 2" Water Service At Sidewalk	1	\$ 12.00	\$ 12.00	1	\$ 12.00	1	\$ 12.00
9.1	Install Cap Ex 2" Water Service At Sidewalk	1	\$ 230.00	\$ 230.00	1	\$ 230.00	1	\$ 230.00
9.11	Install Connection To Ex 6"RW	1	\$ 3,659.00	\$ 3,659.00	1	\$ 3,659.00	1	\$ 3,659.00

Amount	This Period	Total To Date
Amount Earned	\$ 325,528.20	\$ 325,528.20
Amount Retained (5%)	\$ (16,276.41)	\$ (16,276.41)
Previous Payments	\$ -	\$ -
Amount Due	\$ 309,251.79	\$ 309,251.79

Estimated Percentage Of Job Completed 42%

Is Contractor's Construction Progress On Schedule? Yes No

I hereby certify that I have carefully inspected the work and as a result of my inspection and to the best of my knowledge and belief, the quantities shown in this estimate are correct and have not been shown in previous estimates and the work has been performed in accordance with the contract documents.

Date: 10/13/2023
Weka, Inc.
Name of Contractor
By: Steve Miller
Project Manager
Title

TEMESCAL VALLEY WATER DISTRICT

By: Justin Scheidel
Engineer

By: _____
Inspector

Contractor:
Weka, Inc.
236 W. Orange Show Road, #114
San Bernardino, CA. 92408
Owner:
Temescal Valley Water District
22646 Temescal Canyon Road.
Corona, CA. 92883

Project: 2023 Non-Potable Water Conversion

Partial Pay Estimate #: 001.2
Period Ending: 10/13/2023

Item No.	BID SCHEDULE Description	Unit	Qty	Unit		Pay Est 1		Totals to Date		% Complete
				Price	Amount	Qty	Amount	Qty	Amount	
Original Bid:										
1	General Requirements	LS	1	\$6,903.00	\$6,903.00	1	\$6,903.00	1	\$6,903.00	100.00%
2	Mobilization / Demobilization	LS	1	\$35,000.00	\$35,000.00	1	\$28,000.00	1	\$28,000.00	80.00%
3	Excavation Safety Measures	LS	1	\$2,800.00	\$2,800.00	1	\$1,400.00	1	\$1,400.00	50.00%
4	Wildrose Business Park Conversion									
4.01	Furnish 2" Temp Blow-Off Assembly Per Std WB-05	EA	1	\$3,105.00	\$3,105.00	1	\$2,018.25	1	\$2,018.25	65.00%
4.02	Install 2" Temp Blow-Off Assembly Per Std WB-05	EA	1	\$2,947.00	\$2,947.00		\$0.00	0	\$0.00	0.00%
4.03	Furnish 4" Isolation Valve Per Std W-25	EA	3	\$1,452.00	\$4,356.00	3	\$2,831.40	3	\$2,831.40	65.00%
4.04	Install 4" Isolation Valve Per Std W-25	EA	3	\$543.00	\$1,629.00		\$0.00	0	\$0.00	0.00%
4.05	Furnish 8" 20 Foot Long Sleeve To Be Installed Where Recycled Line Passes Under Sewer Line.	EA	3	\$602.00	\$1,806.00		\$1,173.90	0	\$1,173.90	65.00%
4.06	Install 8" 20 Foot Long Sleeve To Be Installed Where Recycled Line Passes Under Sewer Line.	EA	3	\$1,268.00	\$3,804.00		\$0.00	0	\$0.00	0.00%
4.07	Install Thrust Block Per Std W-22	EA	3	\$76.00	\$228.00		\$0.00	0	\$0.00	0.00%
4.08	Furnish Connection To Ex RW Line Per Detail 1 D-2	EA	1	\$4,316.00	\$4,316.00	1	\$2,805.40	1	\$2,805.40	65.00%
4.09	Install Connection To Ex RW Line Per Detail 1 D-2	EA	1	\$3,968.00	\$3,968.00		\$0.00	0	\$0.00	0.00%
4.10	Install 12" Restrained Coupling	EA	1	\$227.00	\$227.00		\$0.00	0	\$0.00	0.00%
4.11	Install 12" Mechanical Restraints	EA	2	\$114.00	\$228.00		\$0.00	0	\$0.00	0.00%
4.12	Install 4" Flanged Gate Valve	EA	1	\$228.00	\$228.00		\$0.00	0	\$0.00	0.00%
4.13	Install 4" Restrained FL Adapter	EA	1	\$114.00	\$114.00		\$0.00	0	\$0.00	0.00%
4.14	Install 12"x4" DI Tee (MJxMJxFL)	EA	1	\$228.00	\$228.00		\$0.00	0	\$0.00	0.00%
4.15	Install 12" DR 14 C900 PVC Purple	EA	5	\$219.00	\$1,095.00		\$0.00	0	\$0.00	0.00%
4.16	Furnish 4" Restrained TEE	EA	1	\$556.00	\$556.00	1	\$361.40	1	\$361.40	65.00%
4.17	Install 4" Restrained TEE	EA	1	\$348.00	\$348.00		\$0.00	0	\$0.00	0.00%
4.18	Furnish 1" Proposed Service Per Std W-7 (Plastic Coated Soft Copper)	EA	6	\$1,211.00	\$7,266.00	6	\$4,722.90	6	\$4,722.90	65.00%
4.19	Install 1" Proposed Service Per Std W-7 (Plastic Coated Soft Copper)	EA	6	\$1,922.00	\$11,532.00		\$0.00	0	\$0.00	0.00%
4.20	Furnish Ex Irrigation Meter With Backflow Assembly - Remove & Replace Per Detail 2 & 3 On D-2 After New	EA	6	\$885.00	\$5,310.00	6	\$3,451.50	6	\$3,451.50	65.00%
4.21	Install Ex Irrigation Meter With Backflow Assembly - Remove & Replace Per Detail 2 & 3 On D-2 After New	EA	6	\$929.00	\$5,574.00		\$0.00	0	\$0.00	0.00%
4.22	Install 2" Copper	LF	8	\$228.00	\$1,824.00		\$0.00	0	\$0.00	0.00%
4.23	Install 2" Ball Valve	EA	1	\$353.00	\$353.00		\$0.00	0	\$0.00	0.00%
4.24	Install 2" 90° Copper Elbow	EA	2	\$228.00	\$456.00		\$0.00	0	\$0.00	0.00%
4.25	Install 2" Union	EA	2	\$228.00	\$456.00		\$0.00	0	\$0.00	0.00%
4.26	Furnish 4" DR 14 C900 PVC Recycled Water Line	LF	629	\$11.00	\$6,919.00	629	\$4,497.35	629	\$4,497.35	65.00%
4.27	Install 4" DR 14 C900 PVC Recycled Water Line	LF	629	\$212.00	\$133,348.00		\$0.00	0	\$0.00	0.00%
4.28	Pothole	EA	12	\$516.00	\$6,192.00		\$0.00	0	\$0.00	0.00%

236 W. Orange Show Road, #114
 San Bernardino, CA. 92408
Owner:
 Temescal Valley Water District
 22646 Temescal Canyon Road.
 Corona, CA. 92883

Partial Pay Estimate #: 001.2
Period Ending: 10/13/2023

Item No.	BID SCHEDULE		Unit		Pay Est 1		Totals to Date		% Complete	
	Description	Unit	Qty	Price	Amount	Qty	Amount	Qty		Amount
5	Wildrose Community Park Conversion									
5.01	Furnish 2" Recycled Water Service Per Std W-8 (Plastic Coated Soft Copper)	LF	168	\$46.00	\$7,728.00	168	\$7,728.00	168	\$7,728.00	100.00%
5.02	Install 2" Recycled Water Service Per Std W-8 (Plastic Coated Soft Copper)	LF	168	\$347.00	\$58,296.00	168	\$58,296.00	168	\$58,296.00	100.00%
5.03	Install 2" 90° Elbow	EA	2	\$228.00	\$456.00	2	\$456.00	2	\$456.00	100.00%
5.04	Furnish Ex Irrigation Meter With Backflow Assembly - Remove & Replace Per Detail 2 & 3 On D-2 After New	EA	1	\$1,080.00	\$1,080.00	1	\$702.00	1	\$702.00	65.00%
5.05	Install Ex Irrigation Meter With Backflow Assembly - Remove & Replace Per Detail 2 & 3 On D-2 After New	EA	1	\$992.00	\$992.00		\$0.00	0	\$0.00	0.00%
5.06	Install 2" Copper	LF	8	\$228.00	\$1,824.00		\$0.00	0	\$0.00	0.00%
5.07	Install 2" Ball Valve	EA	1	\$228.00	\$228.00		\$0.00	0	\$0.00	0.00%
5.08	Install 2" 90° Copper Elbow	EA	2	\$228.00	\$456.00		\$0.00	0	\$0.00	0.00%
5.09	Install 2" Union	EA	2	\$228.00	\$456.00		\$0.00	0	\$0.00	0.00%
5.10	Demo Exist Water Fountain	EA	1	\$1,137.00	\$1,137.00		\$0.00	0	\$0.00	0.00%
5.11	Furnish Cap Ex 2" Water Service At Sidewalk	EA	1	\$12.00	\$12.00	1	\$7.80	1	\$7.80	65.00%
5.12	Install Cap Ex 2" Water Service At Sidewalk	EA	1	\$230.00	\$230.00		\$0.00	0	\$0.00	0.00%
6	Wildrose Ranch HOA Conversion									
6.01	Furnish 2" Recycled Water Service Per Std W-8 (Plastic Coated Soft Copper)	LF	78	\$59.00	\$4,602.00	78	\$4,602.00	78	\$4,602.00	100.00%
6.02	Install 2" Recycled Water Service Per Std W-8 (Plastic Coated Soft Copper)	LF	78	\$419.00	\$32,682.00	78	\$32,682.00	78	\$32,682.00	100.00%
6.03	Install 2" 90° Elbow	EA	1	\$228.00	\$228.00	1	\$228.00	1	\$228.00	100.00%
6.04	Furnish Ex Irrigation Meter With Backflow Assembly - Remove & Replace Per Detail 2 & 3 On D-2 After New	EA	1	\$874.00	\$874.00	1	\$568.10	1	\$568.10	65.00%
6.05	Install Ex Irrigation Meter With Backflow Assembly - Remove & Replace Per Detail 2 & 3 On D-2 After New	EA	1	\$948.00	\$948.00		\$0.00	0	\$0.00	0.00%
6.06	Install 2" Copper	LF	8	\$228.00	\$1,824.00		\$0.00	0	\$0.00	0.00%
6.07	Install 2" Ball Valve	EA	1	\$228.00	\$228.00		\$0.00	0	\$0.00	0.00%
6.08	Install 2" 90° Copper Elbow	EA	2	\$228.00	\$456.00		\$0.00	0	\$0.00	0.00%
6.09	Install 2" Union	EA	2	\$228.00	\$456.00		\$0.00	0	\$0.00	0.00%
6.10	Furnish Cap Ex 2" Water Service At Sidewalk	EA	1	\$12.00	\$12.00	1	\$7.80	1	\$7.80	65.00%
6.11	Install Cap Ex 2" Water Service At Sidewalk	EA	1	\$230.00	\$230.00		\$0.00	0	\$0.00	0.00%
6.12	Install 2" Schedule 40 PVC	LF	20	\$210.00	\$4,200.00		\$0.00	0	\$0.00	0.00%
6.13	Install 2" TEE	EA	2	\$228.00	\$456.00		\$0.00	0	\$0.00	0.00%
6.14	Furnish 2" Ball Valve	EA	3	\$437.00	\$1,311.00	3	\$852.15	3	\$852.15	65.00%
6.15	Install 2" Ball Valve	EA	3	\$322.00	\$966.00		\$0.00	0	\$0.00	0.00%
6.16	Furnish Irrigation Booster Pump Within Stainless Steel Enclosure Per Pump Detail On D-1	EA	1	\$42,832.00	\$42,832.00	1	\$27,840.80	1	\$27,840.80	65.00%
6.17	Install Irrigation Booster Pump Within Stainless Steel Enclosure Per Pump Detail On D-1	EA	1	\$17,168.00	\$17,168.00		\$0.00	0	\$0.00	0.00%
6.18	Furnish 2" Conduit From Ex Cabinet To Proposed Booster Pump	LF	20	\$79.00	\$1,580.00	20	\$1,027.00	20	\$1,027.00	65.00%
6.19	Install 2" Conduit From Ex Cabinet To Proposed Booster Pump	LF	20	\$245.00	\$4,900.00		\$0.00	0	\$0.00	0.00%

236 W. Orange Show Road, #114
 San Bernardino, CA. 92408
Owner:
 Temescal Valley Water District
 22646 Temescal Canyon Road.
 Corona, CA. 92883

Partial Pay Estimate #: 001.2
Period Ending: 10/13/2023

Item No.	BID SCHEDULE Description	Unit	Qty	Unit Price	Amount	Pay Est 1		Totals to Date		% Complete
						Qty	Amount	Qty	Amount	
7	Sycamore Creek Community Park Conversion									
7.01	Furnish 4" C900 DR14 PVC Pipe	LF	862	\$12.00	\$10,344.00	862	\$6,723.60	862	\$6,723.60	65.00%
7.02	Install 4" C900 DR14 PVC Pipe	LF	862	\$206.00	\$177,572.00		\$0.00	0	\$0.00	0.00%
7.03	Furnish 2" Manual Air Valve Per Std WA-01	EA	1	\$2,861.00	\$2,861.00	1	\$1,859.65	1	\$1,859.65	65.00%
7.04	Install 2" Manual Air Valve Per Std WA-01	EA	1	\$847.00	\$847.00		\$0.00	0	\$0.00	0.00%
7.05	Furnish 1" Water Service Lateral (70' Lat)	EA	1	\$2,193.00	\$2,193.00	1	\$1,425.45	1	\$1,425.45	65.00%
7.06	Install 1" Water Service Lateral (70' Lat)	EA	1	\$2,892.00	\$2,892.00		\$0.00	0	\$0.00	0.00%
7.07	Furnish 2" Blowoff Per Std WB-01	EA	1	\$2,751.00	\$2,751.00	1	\$1,788.15	1	\$1,788.15	65.00%
7.08	Install 2" Blowoff Per Std WB-01	EA	1	\$2,871.00	\$2,871.00		\$0.00	0	\$0.00	0.00%
7.09	Install Thrust Block Per Std W-22	EA	1	\$76.00	\$76.00		\$0.00	0	\$0.00	0.00%
7.10	Furnish Connection To Ex RW Line Per Detail 1 D-1	EA	1	\$284.00	\$284.00	1	\$184.60	1	\$184.60	65.00%
7.11	Install Connection To Ex RW Line Per Detail 1 D-1	EA	1	\$0.00	\$0.00		\$0.00	0	\$0.00	#DIV/0!
7.12	Install 12" Restrained Coupling	EA	1	\$228.00	\$228.00		\$0.00	0	\$0.00	0.00%
7.13	Install 12" Mechanical Joint Restraints	EA	2	\$228.00	\$456.00		\$0.00	0	\$0.00	0.00%
7.14	Install 4" Gate Valve	EA	1	\$228.00	\$228.00		\$0.00	0	\$0.00	0.00%
7.15	Install 4" Restrained Flange Adapter	EA	1	\$114.00	\$114.00		\$0.00	0	\$0.00	0.00%
7.16	Install 12"x4" DI Tee (MJxMJxFL)	EA	1	\$228.00	\$228.00		\$0.00	0	\$0.00	0.00%
7.17	Install 12" C900 DR14 PVC	LF	5	\$401.00	\$2,005.00		\$0.00	0	\$0.00	0.00%
7.18	Install Thrust Block Per Std W-22	EA	1	\$263.00	\$263.00		\$0.00	0	\$0.00	0.00%
7.19	Furnish Ex Irrigation Meter With Backflow Assembly - Remove & Replace Per Detail 2 & 3 On D-2 After New	EA	1	\$1,080.00	\$1,080.00	1	\$702.00	1	\$702.00	65.00%
7.20	Install Ex Irrigation Meter With Backflow Assembly - Remove & Replace Per Detail 2 & 3 On D-2 After New	EA	1	\$992.00	\$992.00		\$0.00	0	\$0.00	0.00%
7.21	Install 2" Copper	LF	8	\$228.00	\$1,824.00		\$0.00	0	\$0.00	0.00%
7.22	Install 2" Ball Valve	EA	1	\$228.00	\$228.00		\$0.00	0	\$0.00	0.00%
7.23	Install 2" 90° Copper Elbow	EA	2	\$228.00	\$456.00		\$0.00	0	\$0.00	0.00%
7.24	Install 2" Union	EA	2	\$228.00	\$456.00		\$0.00	0	\$0.00	0.00%
8	Sycamore Creek Fire Station Conversion									
8.01	Furnish Ex Irrigation Meter With Backflow Assembly - Remove & Replace Per Detail 2 & 3 On D-2 After New	EA	1	\$1,080.00	\$1,080.00	1	\$702.00	1	\$702.00	65.00%
8.02	Install Ex Irrigation Meter With Backflow Assembly - Remove & Replace Per Detail 2 & 3 On D-2 After New	EA	1	\$992.00	\$992.00		\$0.00	0	\$0.00	0.00%
8.03	2" Copper	LF	8	\$228.00	\$1,824.00		\$0.00	0	\$0.00	0.00%
8.04	2" Ball Valve	EA	1	\$228.00	\$228.00		\$0.00	0	\$0.00	0.00%
8.05	2" 90° Copper Elbow	EA	2	\$228.00	\$456.00		\$0.00	0	\$0.00	0.00%
8.06	2" Union	EA	2	\$228.00	\$456.00		\$0.00	0	\$0.00	0.00%
8.07	Furnish 2" Recycled Water Service Per Std W-8 (Plastic Coated Soft Copper)	LF	70	\$62.00	\$4,340.00	70	\$4,340.00	70	\$4,340.00	100.00%
8.08	Install 2" Recycled Water Service Per Std W-8 (Plastic Coated Soft Copper)	LF	70	\$512.00	\$35,840.00	70	\$35,840.00	70	\$35,840.00	100.00%
8.09	Connection To Ex 6" RW	EA	1	\$3,659.00	\$3,659.00	1	\$3,659.00	1	\$3,659.00	100.00%
8.10	Furnish Cap Ex 2" Water Service At Sidewalk	EA	1	\$12.00	\$12.00	1	\$12.00	1	\$12.00	100.00%
8.11	Cap Ex 2" Water Service At Sidewalk	EA	1	\$230.00	\$230.00	1	\$230.00	1	\$230.00	100.00%

236 W. Orange Show Road, #114
 San Bernardino, CA. 92408
Owner:
 Temescal Valley Water District
 22646 Temescal Canyon Road.
 Corona, CA. 92883

Partial Pay Estimate #: 001.2
Period Ending: 10/13/2023

Item No.	BID SCHEDULE Description	Unit	Qty	Unit		Pay Est 1		Totals to Date		% Complete
				Price	Amount	Qty	Amount	Qty	Amount	
9	Sycamore Creek HOA Conversion									
9.01	Furnish 2" Recycled Water Service Per Std W-8 (Plastic Coated Soft Copper)	LF	232	\$41.00	\$9,512.00	232	\$9,512.00	232	\$9,512.00	100.00%
9.02	Install 2" Recycled Water Service Per Std W-8 (Plastic Coated Soft Copper)	LF	232	\$262.00	\$60,784.00	232	\$60,784.00	232	\$60,784.00	100.00%
9.03	Furnish Ex Irrigation Meter With Backflow Assembly - Remove & Replace Per Detail 2 & 3 On D-2 After New	EA	1	\$1,080.00	\$1,080.00	1	\$702.00	1	\$702.00	65.00%
9.04	Install Ex Irrigation Meter With Backflow Assembly - Remove & Replace Per Detail 2 & 3 On D-2 After New	EA	1	\$992.00	\$992.00		\$0.00	0	\$0.00	0.00%
9.05	Install 2" Copper	LF	8	\$228.00	\$1,824.00		\$0.00	0	\$0.00	0.00%
9.06	Install 2" Ball Valve	EA	1	\$228.00	\$228.00		\$0.00	0	\$0.00	0.00%
9.07	Install 2" 90° Copper Elbow	EA	2	\$228.00	\$456.00		\$0.00	0	\$0.00	0.00%
9.08	Install 2" Union	EA	2	\$228.00	\$456.00		\$0.00	0	\$0.00	0.00%
9.09	Furnish Cap Ex 2" Water Service At Sidewalk	EA	1	\$12.00	\$12.00	1	\$12.00	1	\$12.00	100.00%
9.10	Install Cap Ex 2" Water Service At Sidewalk	EA	1	\$230.00	\$230.00	1	\$230.00	1	\$230.00	100.00%
9.11	Install Connection To Ex 6"RW	EA	1	\$3,659.00	\$3,659.00	1	\$3,659.00	1	\$3,659.00	100.00%
10	As-built, Record Drawings and O&M Manuals	LS	1	\$1,000.00	\$1,000.00		\$0.00	0	\$0.00	0.00%
11	All other Work Required to Complete the Project	LS	1	\$500.00	\$500.00		\$0.00	0	\$0.00	0.00%

Total Original Bid					\$783,063.00		\$325,528.20		\$325,528.20	41.57%
Change Orders:										
					\$0.00		\$0.00		\$0.00	0.00%
					\$0.00		\$0.00		\$0.00	0.00%
Total Change Orders					\$0.00		\$0.00		\$0.00	

TOTAL BID AND CHANGE ORDERS					\$783,063.00		\$325,528.20		\$325,528.20	41.57%
------------------------------------	--	--	--	--	---------------------	--	---------------------	--	---------------------	---------------

CONDITIONAL WAIVER AND RELEASE ON PROGRESS PAYMENT

NOTICE: THIS DOCUMENT WAIVES THE CLAIMANT'S LIEN, STOP PAYMENT NOTICE, AND PAYMENT BOND RIGHTS EFFECTIVE ON RECEIPT OF PAYMENT. A PERSON SHOULD NOT RELY ON THIS DOCUMENT UNLESS SATISFIED THAT THE CLAIMANT HAS RECEIVED PAYMENT.

Identifying Information

Name of Claimant:

Name of Customer:

Job Location:

Owner:

Through Date:

Conditional Waiver and Release

This document waives and releases lien, stop payment notice, and payment bond rights the claimant has for labor and service provided, and equipment and material delivered, to the customer on this job through the Through Date of this document. Rights based upon labor or service provided, or equipment or material delivered, pursuant to a written change order that has been fully executed by the parties prior to the date that this document is signed by the claimant, are waived and released by this document, unless listed as an Exception below. This document is effective only on the claimant's receipt of payment from the financial institution on which the following check is drawn:

Maker of Check:

Amount of Check: \$

Check Payable to:

Exceptions

This document does not affect any of the following:

- (1) Retentions.
 - (2) Extras for which the claimant has not received payment.
 - (3) The following progress payments for which the claimant has previously given a conditional waiver and release but has not received payment:
 - Date(s) of waiver and release: _____
 - Amount(s) of unpaid progress payment(s): \$ _____
 - (4) Contract rights, including (A) a right based on rescission, abandonment, or breach of contract, and (B) the right to recover compensation for work not compensated by the payment.
-

Signature

Claimant's Signature: *Kari Saputo*

Claimant's Title:

Date of Signature:
